

Preparation

Part Number: PTR11-52071

Kit Contents

| Item # | Quantity Reqd. | Description |
|--------|----------------|----------------|
| 1 | 1 | Sway Bar, Rear |
| 2 | | |
| 3 | | |
| | | |

Hardware Bag Contents

| Item # | Quantity Reqd. | Description |
|--------|----------------|--------------------|
| 1 | 2 | Nuts 10 mm |
| 2 | 2 | Bolts 10x1.5x30 mm |
| 3 | 2 | M10 washers |
| | | |

Additional Items Required For Installation

| Item # | Quantity Reqd. | Description |
|--------|----------------|-------------|
| 1 | | |
| 2 | | |
| 3 | | |
| | | |

Conflicts

| |
|------|
| None |
|------|

Recommended Tools

| Personal & Vehicle Protection | Notes |
|---|--------------|
| Jack Stand | |
| | |
| | |
| Special Tools | Notes |
| Vehicle Lift or Car Jack & vehicle stands | |
| | |
| | |
| Installation Tools | Notes |
| 14mm, 15mm sockets | |
| Torque Wrench | |
| | |
| Special Chemicals | Notes |
| | |
| | |

General Applicability

| |
|------------------------------------|
| Yaris (Liftback, Sedan, & S Sedan) |
|------------------------------------|





Recommended Sequence of Application

| Item # | Accessory |
|--------|-----------|
| 1 | |
| 2 | |
| 3 | |
| | |

Vehicle Service Parts (may be required for reassembly)

| Item # | Quantity Reqd. | Description |
|--------|----------------|-------------|
| 1 | | |
| 2 | | |
| 3 | | |
| | | |

Legend

| | |
|---|--|
|  | STOP: Damage to the vehicle may occur. Do not proceed until process has been complied with. |
|  | OPERATOR SAFETY: Use caution to avoid risk of injury. |
|  | CAUTION: A process that must be carefully observed in order to reduce the risk of damage to the accessory/vehicle and to ensure a quality installation. |
|  | TOOLS & EQUIPMENT: Used in Figures calls out the specific tools and equipment recommended for this process. |
|  | REVISION MARK: This mark highlights a change in installation with respect to previous issue. |

1. Raise rear end of vehicle.



(a) Be sure to secure vehicle with jack stands if using a car jack.



(b) Be sure to use the jack-up points that are provided on the body when raising the vehicle with the jack.



(c) Never place the jack under the torsion beam, spring seat, trailing arm, or bushing of the rear suspension.

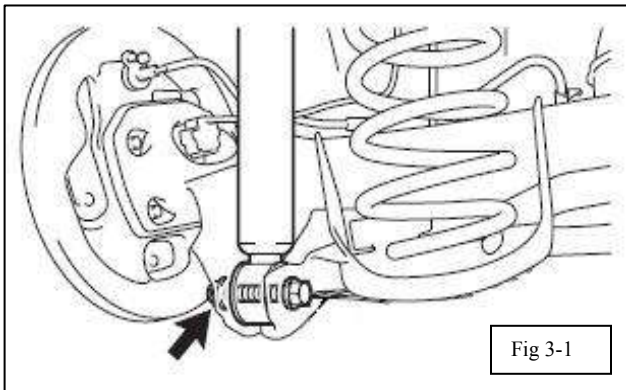

Fig 3-1

2. Remove rear wheels.

3. Remove rear shock absorber nuts. (Fig 3-1)

- (a) Loosen by turning the bolt head **NOT** the nut. Then remove both nuts.
- (b) Leave one bolt in place and back the other bolt out until flush with the shock mount.

4. Install sway bar.

- (a) Hang sway bar off of shock bolt and position opposite end of bar over the flush seated bolt.
- (b) Fully seat flush mounted bolt so that it will hold the weight of the sway bar.
- (c) Install provided hardware into forward mounting holes on the sway bar once they line up with the corresponding mounting holes on the beam axle. (Fig 4-1)

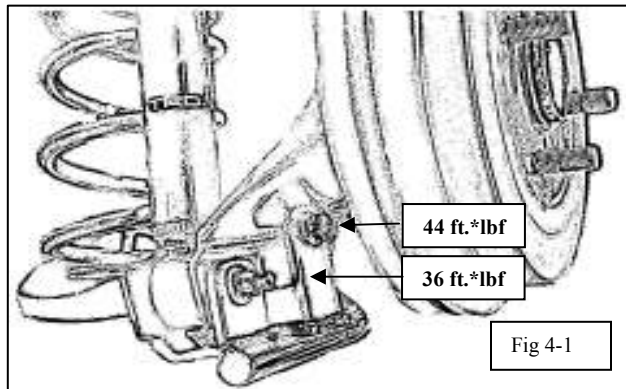

Fig 4-1

Torque: 59 N*m (604 kgf*cm, 44 ft.*lbf)

- (d) Tighten nuts on shock absorber mounts. (tighten by turning the bolt head not the nut.)

Torque: 49 N*m (500kgf*cm, 36ft.*lbf)

5. Install rear wheels. (as shown in Fig 5-1.)

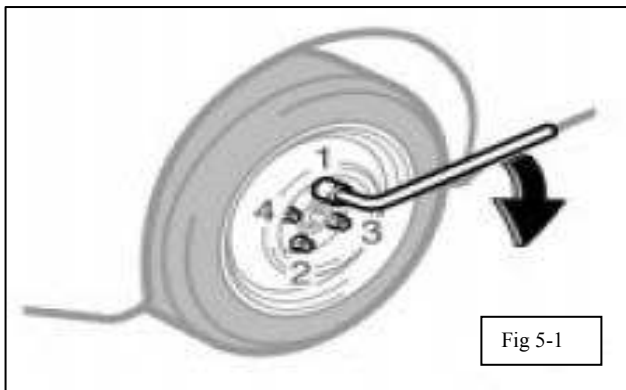

Fig 5-1

Torque: 103 N*m (1,050 kgf*cm, 76 ft.*lbf)

Checklist - these points **MUST** be checked to ensure a quality installation.

Check:

Look For:

Accessory Function Checks

- Confirm sway bar does not touch beam axle anywhere except its mounting points.
-

Vehicle Function Checks

- Test drive vehicle if practical and confirm there is no unwanted noise from the suspension
- Do not exceed posted speed limits.
-

Clunks, Creaks, Rattles