

Preparation

Part Number: PT212-35053 (C-cab)
PT212-35055 (D-cab)

NOTE: Part number of this accessory may not be the same as the part number shown.

Kit Contents

Item #	Quantity Reqd.	Description
1	1	LHS Board Assembly
2	1	RHS Board Assembly
3		





Vehicle Service Parts (may be required for reassembly)

Item #	Quantity Reqd.	Description
1		
2		
3		

Hardware Bag Contents

Item #	Quantity Reqd.	Description
1	12	M8 x 25 Serrated Flange Screw
2	1	Instruction Sheet
3		

Legend

	STOP: Damage to the vehicle may occur. Do not proceed until process has been complied with.
	OPERATOR SAFETY: Use caution to avoid risk of injury.
	CAUTION: A process that must be carefully observed in order to reduce the risk of damage to the accessory/vehicle and to ensure a quality installation.
	TOOLS & EQUIPMENT: Used in Figures calls out the specific tools and equipment recommended for this process.
	REVISION MARK: This mark highlights a change in installation with respect to previous issue.

Additional Items Required For Installation

Item #	Quantity Reqd.	Description
1		
2		
3		

Conflicts

--

Recommended Tools

Personal & Vehicle Protection	Notes
None	
Special Tools	Notes
None	
Installation Tools	Notes
Screwdriver	Small Slotted
Ratchet	3/8"
Sockets	13 mm (M8), 7/16" (1/4-20)
Extension	3/8" - 3"
Torque Wrench	3/8" Drive (25 lbf-ft)
Special Chemicals	Notes
None	

General Applicability

--

Recommended Sequence of Application

Item #	Accessory
1	
2	
3	

*Mandatory

Care must be taken when installing this accessory to ensure damage does not occur to the vehicle. The installation of this accessory should follow approved guidelines to ensure a quality installation.

These guidelines can be found in the "Accessory Installation Practices" document.

This document covers such items as:-

- Vehicle Protection (use of covers and blankets, cleaning chemicals, etc.).
- Safety (eye protection, rechecking torque procedure, etc.).
- Vehicle Disassembly/Reassembly (panel removal, part storage, etc.).
- Electrical Component Disassembly/Reassembly (battery disconnection, connector removal, etc.).

Please see your Toyota dealer for a copy of this document.

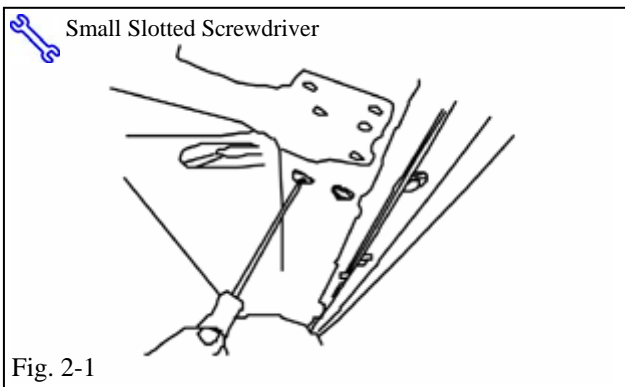
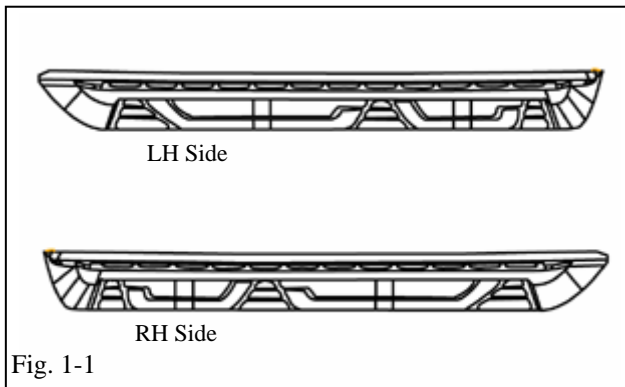

1. Remove Running Board from Packaging.

- (a) Remove running board assembly from package and place on a clean protected surface. The boards are sided (Fig. 1-1)
- (b) Verify kit contents and inspect the running board for damage.

2. Running Board Preparation for Installation (LH/RH Side).

- (a) Verify hardware bag content by referring to the cover page of this instruction sheet.
- (b) With a small slotted screwdriver, remove the plastic plugs covering M8 weld nuts in body of vehicle at 6 points/side. (Fig. 2-2)
- (c) Locate M8 x 25 bolts from kit, install one finger tight, at the center location, upper position. (Fig. 2-3)

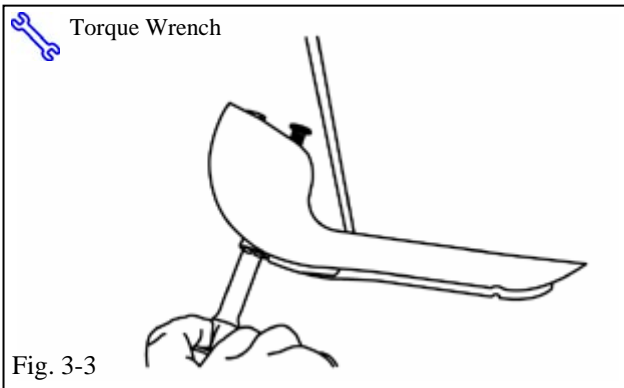
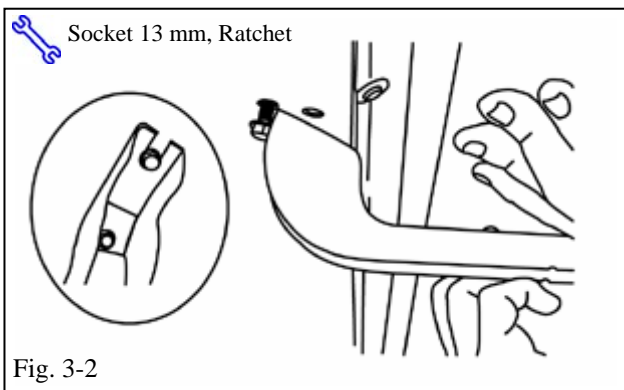
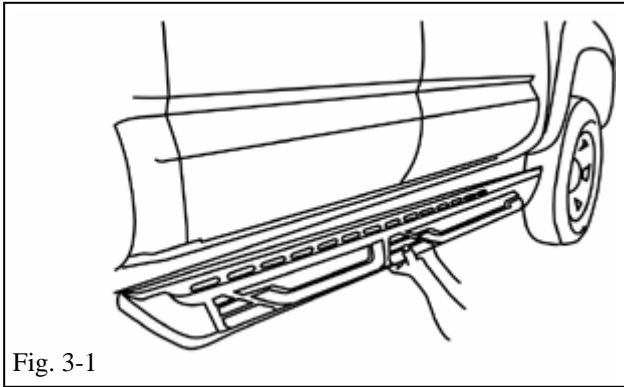

3. Running Board Installation (RH Side).

(a) Lift running board assembly into position. (Fig. 3-1)

(b) Engage slot of center bracket under head of M8 x 25 bolt, slide upwards and snug with socket wrench to secure position. (Fig. 3-2)

 (c) Install other M8 x 25 bolts at remaining locations to secure brackets. Torque all six bolts to 14.4 lbf-ft. (Fig. 3-3)

NOTE: These six (6) M8 bolts have Loctite on their threads.

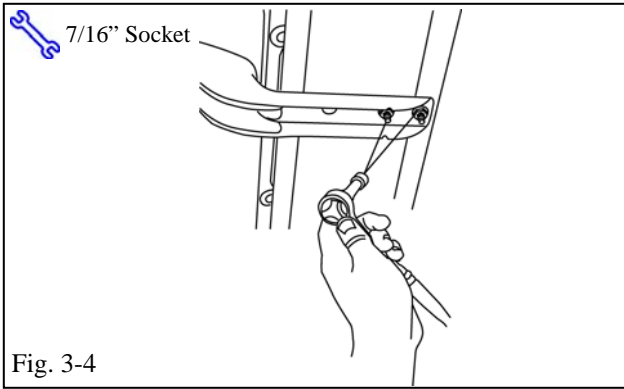

NOTE: If inboard/outboard and/or lateral adjustments are needed, loosen the 1/4 - 20 flange nuts at each of the three (3) bracket locations on the running board. (Fig. 3-4)
Manually slide the running board cover to where there is no interference with the vehicle front fender flare (3 mm minimum clearance) (Fig. 3-5).
Tighten the 1/4 - 20 flange nuts to 8lbf-ft.

4. Running Board Installation (LH Side).

(a) Repeat step 3(a) to 3(c) for left hand side.

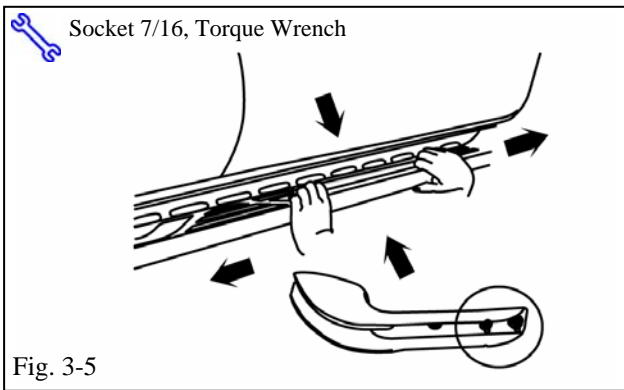

TOYOTA TACOMA 2006 - RUNNING BOARD

Checklist - these points **MUST** be checked to ensure a quality installation.

Check:

Accessory Function Checks

Visual check of running board

 Re-check all bolts for torque

Look For:

No interference with front fender flare.

All bolts must be within $\pm 25\%$

Torque check M8 bolts – 10.8 to 18.0 lbf-ft.

If nuts are loosened for running board adjustment, torque check 1/4-20 nuts – 6 to 10 lbf-ft