

**Part Number: Mounting Kit PT546-52061
Tuner Assy 86180-0W030**

NOTE: Part number of this accessory may not be the same as the part number shown.

Tuner Assy Kit Contents (86180-0W030)

Item #	Quantity Reqd.	Description
1	1	Tuner Assy, Stereo Component

Mounting Kit Contents (PT546-52061)

Item #	Quantity Reqd.	Description
1	1	Ground Cable
2	1	Wire, To Radio Installation
3	2	Tuner Bracket
4	2	Base Bracket
5	1	Template A (to locate Bracket)
6	1	Cushion A (Rear LHS)
7	1	Cushion B (Rear RHS)
8	2	Cushion C (Front LHS, & RHS)
9	1	Antenna
10	3	Hardware Bags
11	1	XM Satellite Radio Brochure

Hardware Bag Contents – 1 (PT546-52061)

Item #	Quantity Reqd.	Description
1	4	Screw (M5xL8)
2	4	Nut (M6)

Hardware Bag Contents – 2 (PT546-52061)

Item #	Quantity Reqd.	Description
1	1	Template B (xA / xB)
2	1	Cord Rail (150mm)
3	1	Cord Rail (200mm)
4	8	Lock Tie B (Antenna Cable)
5	11	Sheet Tape (to Fix Antenna)

Hardware Bag Contents – 3 (PT546-52061)

Item #	Quantity Reqd.	Description
1	1	Cushion Tape (Cord Styling)
2	8	Lock Tie A (AVC-LAN)

Additional Items Required For Installation

Item #	Quantity Reqd.	Description
1	1	Satellite Receiver Cover P/N PT903-52040

Conflicts

--

Recommended Tools

Personal & Vehicle Protection	Notes
Safety Goggles	

Seat Covers	
Floor Protectors	
Special Tools	Notes
Arch (Carpet) Punch	5/16 " Hole Diameter (McMaster P/N: 3427A12)
Installation Tools	Notes
Ratchet	
Extensions	
Sockets	10 mm, 12 mm, 14mm
Torque Wrench	4 N•m (3 lbf•ft), 36 N•m (27 lbf•ft), 42 N•m (31 lbf•ft)
Screwdriver	Philips, #2
Nylon Removal Tool	e.g. Panel Pry Tool #1 Toyota SST # 00002-06001-01
Masking Tape	(2" wide)
Mallet	
Special Chemicals	Notes
Sealant	3M TM Ultra-Pro Body Sealant
Cleaner	3M TM Prep Solvent-70

General Applicability

--

Recommended Sequence of Application





Item #	Accessory
1	TVIP
2	XM Satellite Receiver
3	Audio
4	Subwoofer (Supplier Brand)

*Mandatory

Vehicle Service Parts (may be required for reassembly)

Item #	Quantity Reqd.	Description

Legend

	STOP: Damage to the vehicle may occur. Do not proceed until process has been complied with.
	OPERATOR SAFETY: Use caution to avoid risk of injury.
	CAUTION: A process that must be carefully observed in order to reduce the risk of damage to the accessory/vehicle and to ensure a quality installation.
	TOOLS & EQUIPMENT: Used in Figures calls out the specific tools and equipment recommended for this process.

Parts Description of Tuner Assy (86180-0W030)

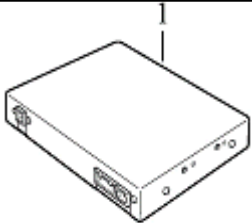

Item #	Parts Name	Parts No.	Qty
1	Tuner	86180-0W030	1

Parts Description of Mounting Kit (PT546-52061)

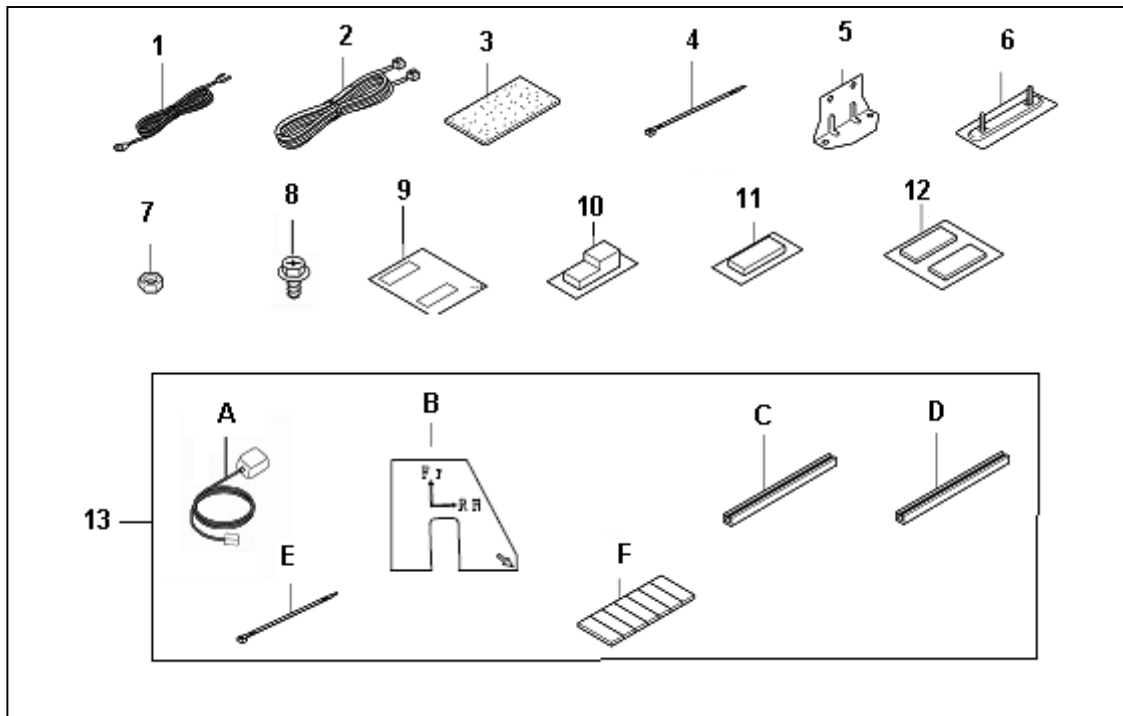

Item #	Parts Name	Qty
1	Ground Cable	1
2	Wire, To Radio Installation	1
3	Cushion Tape (cord styling)	1
4	Lock Tie A (AVC-LAN)	8
5	Tuner Bracket	2
6	Base Bracket	2
7	Nut (M6)	4
8	Screw (M5 x L8)	4
9	Template A (to locate bracket)	1
10	Cushion A (RL-side)	1
11	Cushion B (RR-side)	1
12	Cushion C (FL.FR-side)	2
13	A Antenna	1
	B Template B (to locate antenna for xA / xB)	1
	C Cord Rail A (200 mm) (not used for xA)	1
	D Cord Rail B (150 mm) (not used for xA)	1
	E Lock Tie B (antenna cable)	8
	F Sheet Tape (to fix antenna cable) (2 required, 9 extra for xA)	11

Care must be taken when installing this accessory to ensure damage does not occur to the vehicle. The installation of this accessory should follow approved guidelines to ensure a quality installation.

These guidelines can be found in the "Accessory Installation Practices" document.

This document covers such items as:-

- Vehicle Protection (use of covers and blankets, cleaning chemicals, etc.).
- Safety (eye protection, rechecking torque procedure, etc.).
- Vehicle Disassembly/Reassembly (panel removal, part storage, etc.).
- Electrical Component Disassembly/Reassembly (battery disconnection, connector removal, etc.).

Please see your Toyota dealer for a copy of this document.

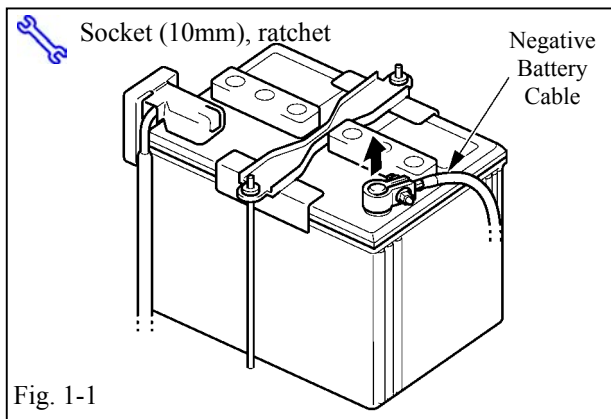

1. Vehicle Disassembly.

(a) Remove the negative battery cable.(Fig. 1-1)



(1) Protect the fender before starting.

(2) Do not touch the positive terminal with any tool when removing cable.

(b) Remove tonneau cover.

(1) Protect the rear bumper.

(c) Remove the deck trim cover (Fig. 1-2) as follows:

(1) Remove clips.

(2) Disengage claws and remove the deck trim cover.

(d) Remove the deck board and tool bag from the cargo area.

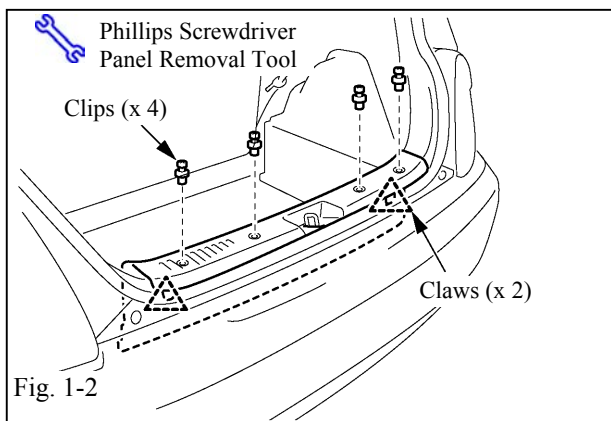

(e) Unscrew and remove the deck floor box. (Fig. 1-3)

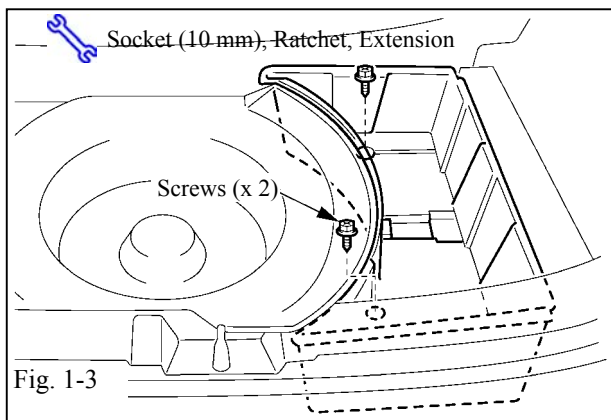

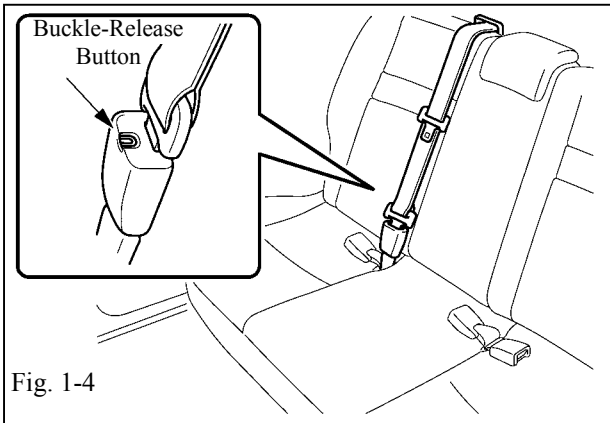

(f) Disconnect the rear center seat belt by pressing the buckle-release button with a non-metal tool

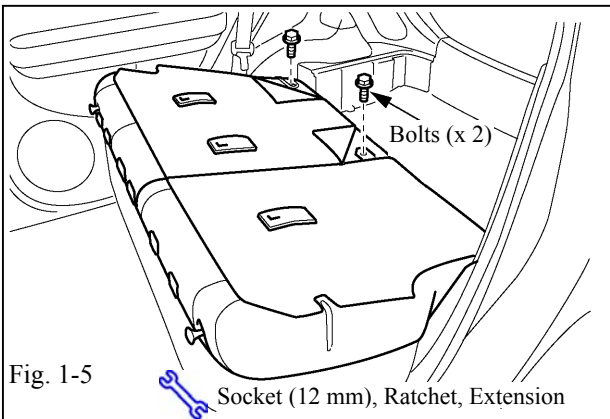

(g) Disassemble the rear seat as follows:

- (1) Fold down the seatback, and then fold back the cover to locate the bolts.
- (2) Unbolt and remove the right rear seatback. (Fig. 1-5)

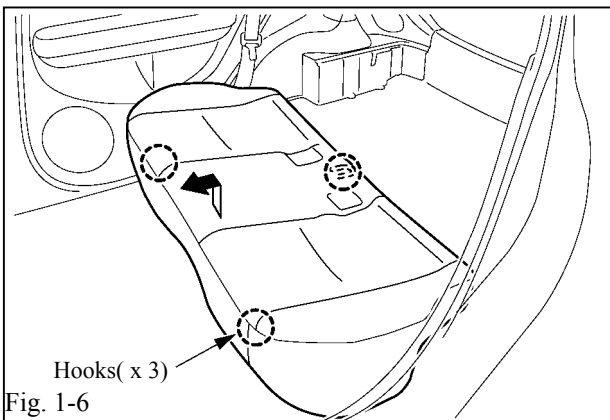

(h) Disengage the hooks and remove the rear seat cushion. (Fig. 1-6)



NOTE: Be careful not to damage the seat, door and other vehicle parts when removing the seat from the vehicle.

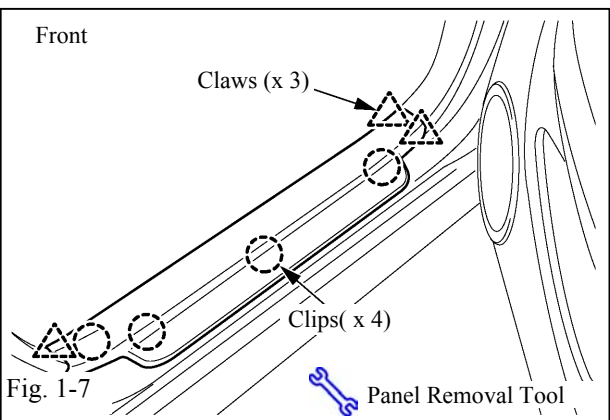

(i) Disengage the clips and claws and remove the front passenger side door scuff plates. (Fig. 1-7)

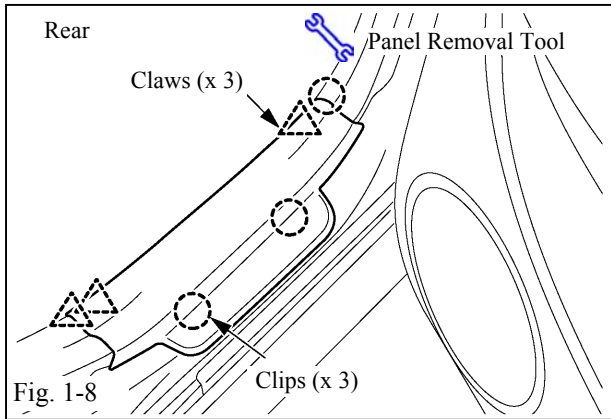

- (j) Disengage the clips and claws and remove the rear passenger side door scuff plates. (Fig. 1-8)

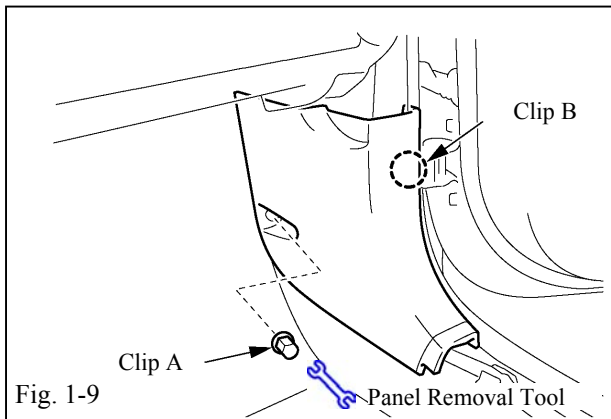

- (k) Remove the passenger side cowl side trim (Fig. 1-9) as follows:
 - (1) Remove clip A.
 - (2) Disengage clip B and remove the cowl side trim.

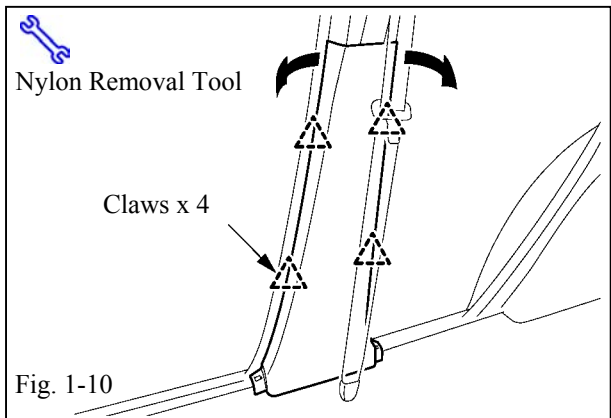

- (l) Disengage the claws and remove the passenger side center pillar garnish lower. (1-10)

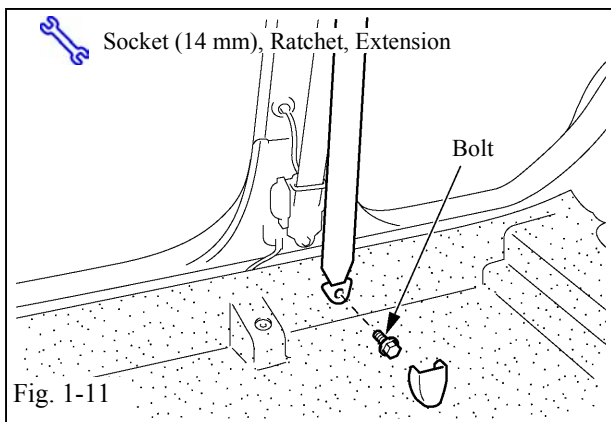

- (m) Disassemble the passenger front seat belt as follows (Fig. 1-11):
 - (1) Remove the passenger front seat belt anchor cover.
 - (2) Unbolt and detach the passenger front seat belt anchor plate.

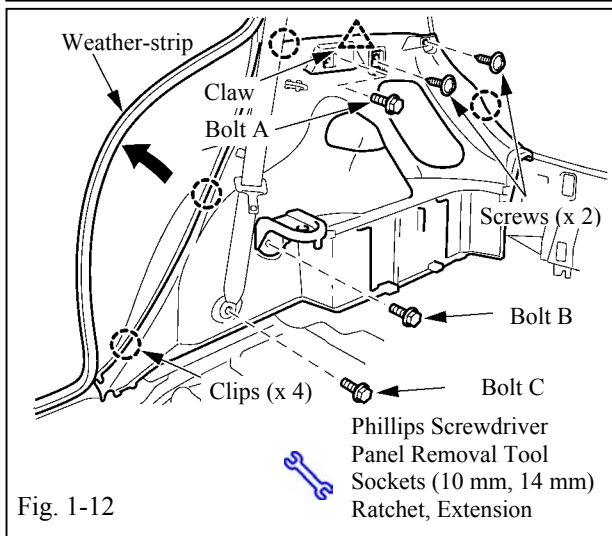

Fig. 1-12

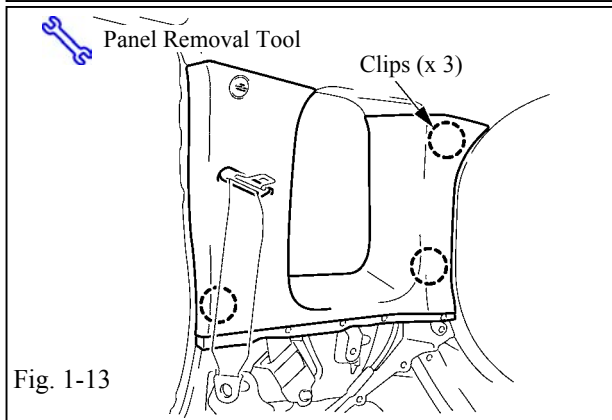

Fig. 1-13

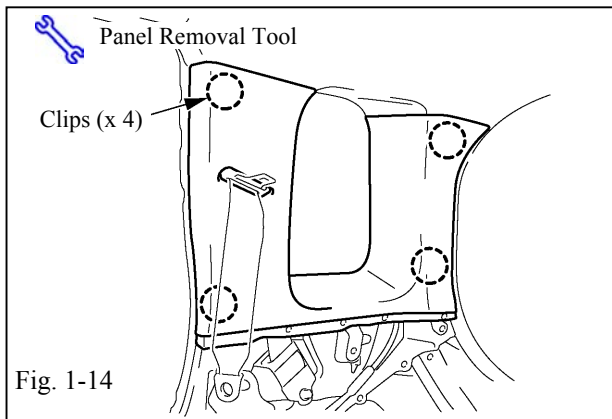

Fig. 1-14

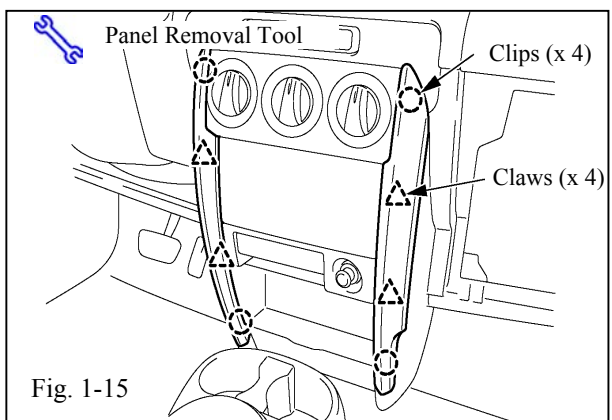

Fig. 1-15

- (n) Remove the passenger side deck trim side panel as follows (Fig. 1-12):
 - (1) Remove screws and bolt A.
 - (2) Remove bolt B, and then remove the rear seatback hinge.
- (o) Remove bolt C and remove the rear seat belt anchor plate.
- (p) Remove the weather-strip (Fig. 1-12)
- (q) Disengage the clips and claws, and then remove the deck trim side panel.

FOR VEHICLES WITH CURTAIN SHIELD AIRBAG ONLY. (Step 1.(r))

“SRS CURTAIN AIRBAG” is shown on the upper left of the roof side inner garnish.

- (r) Remove the passenger side roof inner garnish as follows:
 - (1) Disengage the clips except for the upper left one. (Fig. 1-13)



NOTE: Do not attempt to remove the roof side inner garnish upper left clip. The SRS curtain shield airbag may be damaged.

FOR VEHICLES WITHOUT CURTAIN SHIELD AIRBAG ONLY. (Step 1.(s))

- (s) Remove the passenger side roof inner garnish as follows:
 - (1) Disengage the clips. (Fig. 1-14)
 - (2) Route the rear seat belt through the slot in the roof side inner garnish, then remove it.
- (t) Remove the center cluster as follows:
 - (1) Disengage the clips and claws and remove the instrument cluster finish panel. (Fig. 1-15)

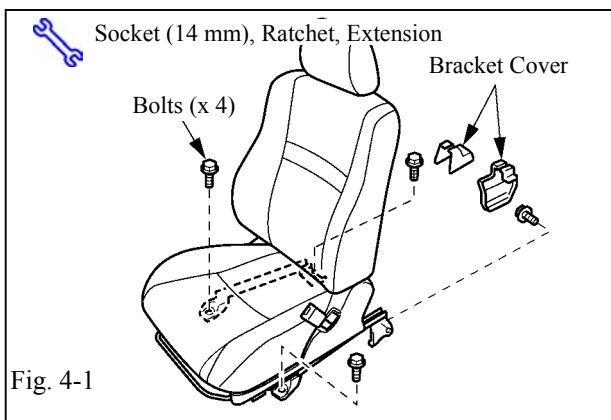
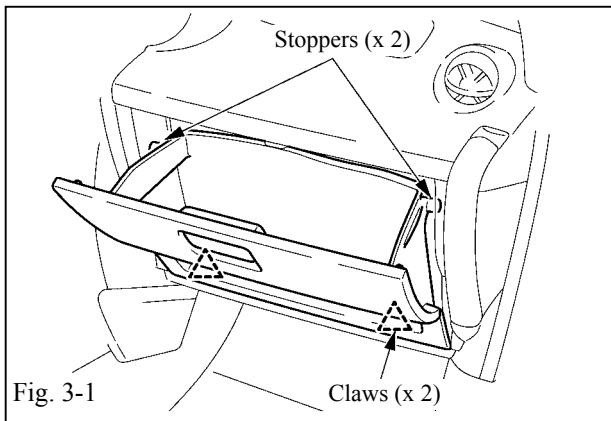
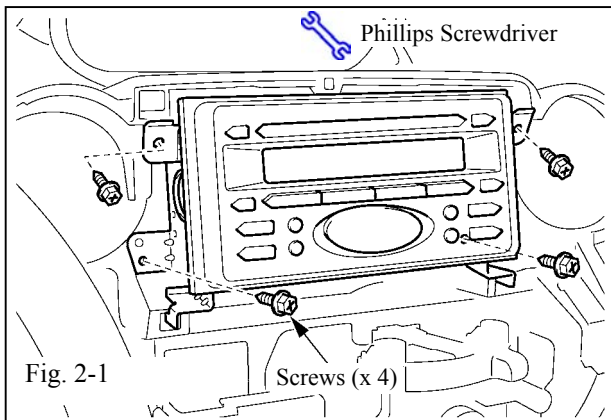
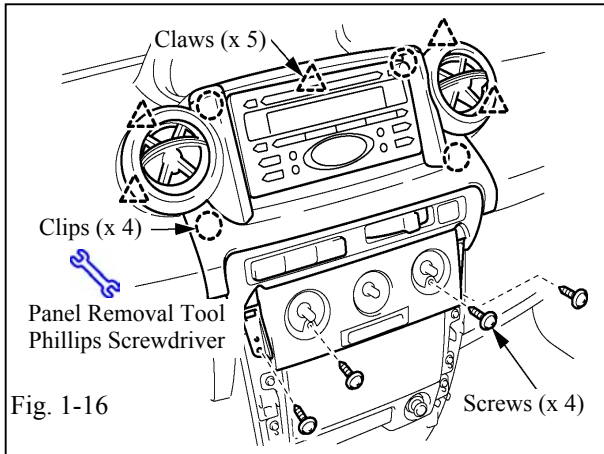

- (2) Disconnect the heater control knobs and remove the four (4) screws. (Fig. 1-16)
- (3) Disengage the clips and claws and remove the instrument cluster finish panel. (Fig. 1-16)
- (4) Disconnect the connectors.

2. Remove the Radio/Player Head Unit.

- (a) Unscrew the four (4) screws, retain the screws, and remove the head unit. (Fig. 2-1)
- (b) Disconnect the connectors.

3. Remove the Glove Compartment Door.

- (a) Squeeze both ends of the box together to fully extend the box, and then remove the stoppers. (Fig. 3-1)
- (b) Disengage the claws, and then remove the glove compartment door.

4. Disassemble Passenger Front Seat.



- (a) Protect the rear seat area, floor, and center console area.
- (b) Remove the seat track bracket covers. (Fig. 4-1)
- (c) Remove the rear seat bolts.
- (d) Slide the seat back.
- (e) Remove the front seat bolts.
- (f) Disconnect the connectors.
- (g) Tilt the seat rearwards, exposing the floor under the front passenger seat, and lay the seat in the rear seat area.

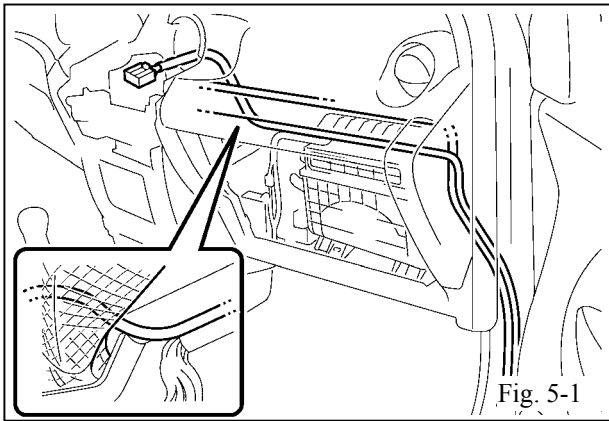

5. Route the Satellite Tuner Cable.

- (a) Route the tuner cable, foam side, from the center cluster to the head unit. (Fig. 5-1)
- (b) Secure the tuner cable with the vehicle wire harness. Install five (5) lock ties A as shown. (Fig. 5-2)

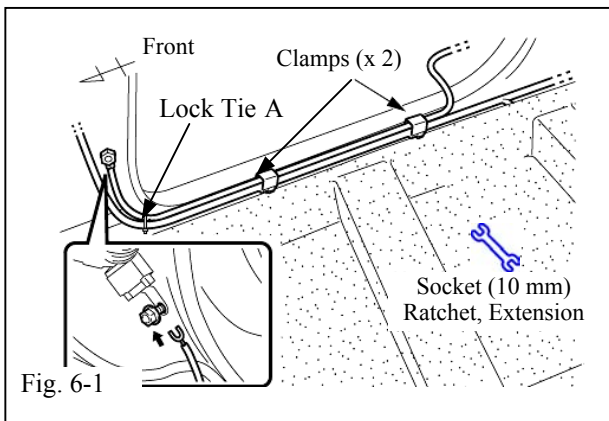
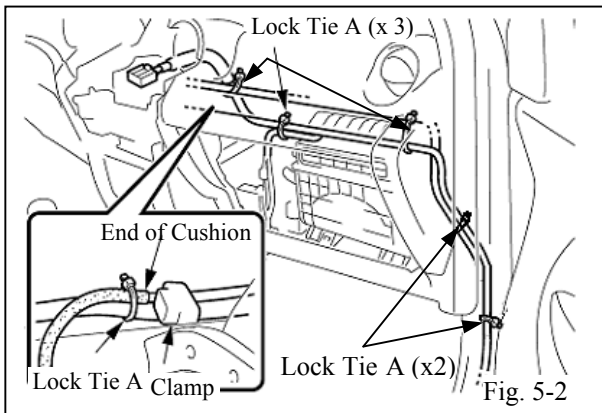

6. Route the Tuner Ground Cable.

- (a) Install the end of the tuner ground cable onto the bolt located on the cowl side. Secure to tuner wire with lock tie as shown. (Fig. 6-1)
- (b) Secure the tuner ground cable and tuner cable using the vehicle wire harness clamps.

7. Install the Antenna.

- (a) Clean the template (template B) mounting area with 3M™ Prep Solvent-70. (Fig. 7-1)
- (b) Position template B on the near right corner of the roof as shown. Secure the template with masking tape. (Fig. 7-1)

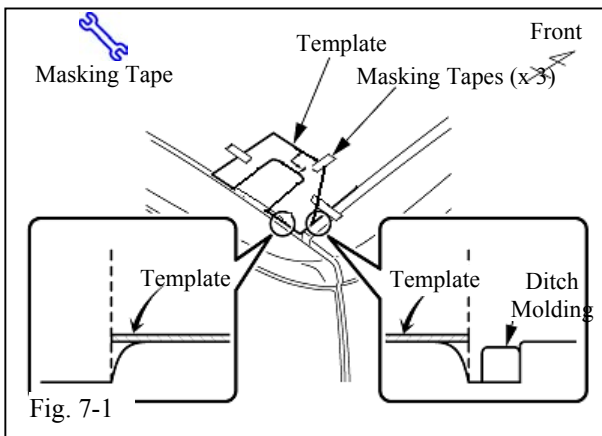

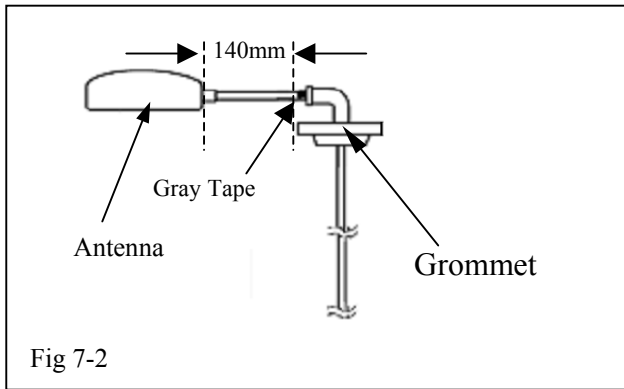

(c) The grommet must be slid from position as shipped.



(1) Slowly slide grommet to the gray tape 140mm from the ray dome of the antenna. Use caution to avoid damage to the wire when sliding the grommet. (Fig. 7-2)

(d) Remove the release paper from the back of antenna, and then affix the antenna onto the roof. (Fig. 7-3)

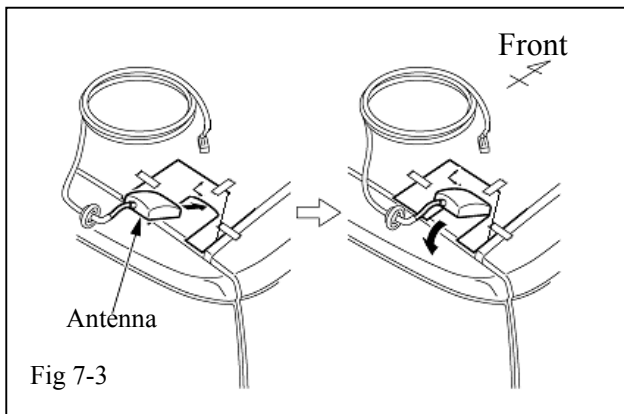

(1) Align the front edge of the antenna with the template as shown and install it carefully.



(2) Once attached, the antenna cannot be easily removed.

8. Route Antenna Cable through Body Opening.

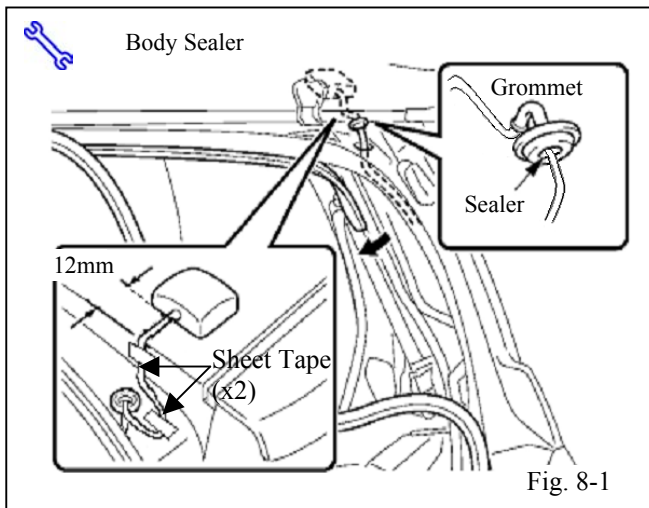

(a) Remove and discard the grommet covering the body opening.

(b) The roof and roof/hatch area where the sheet tape attaches must be cleaned with 3M™ Prep Solvent-70. (see Fig. 8-1)

(c) After cleaning, apply 3M™ Ultra-Pro Body Sealant to the back side of the grommet as shown, then insert the grommet into the body opening. (Fig. 8-1)

(1) Secure the antenna cable with sheet tape so the closed door does not contact or pinch the cable (Fig. 8-1).

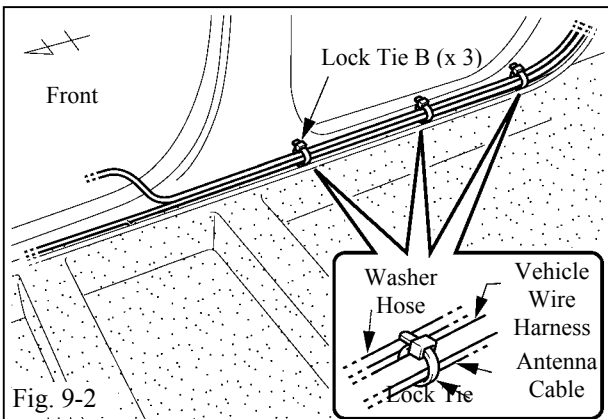
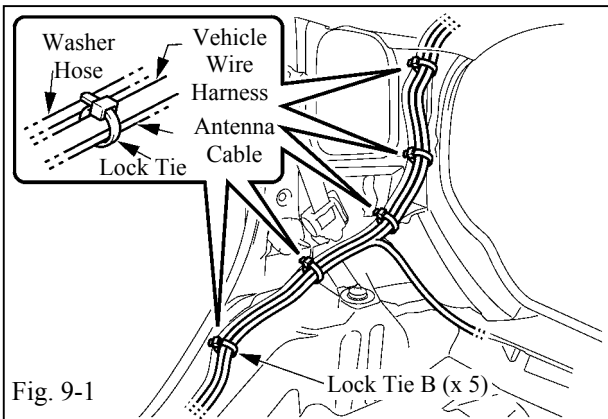

9. Secure the Antenna Cable.

- (a) Secure the antenna cable to the vehicle wire harness using the five (5) lock ties (type B). (Fig. 9-1)
- (b) Secure the antenna cable to the vehicle wire harness using the three (3) lock ties (type B). (Fig. 9-2)



NOTE: Do **NOT** secure the antenna cable to the washer hose.

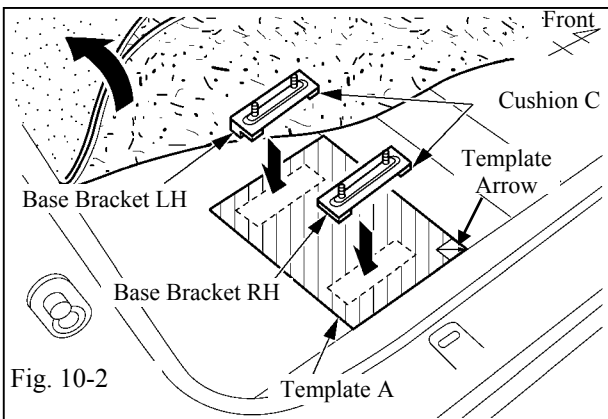
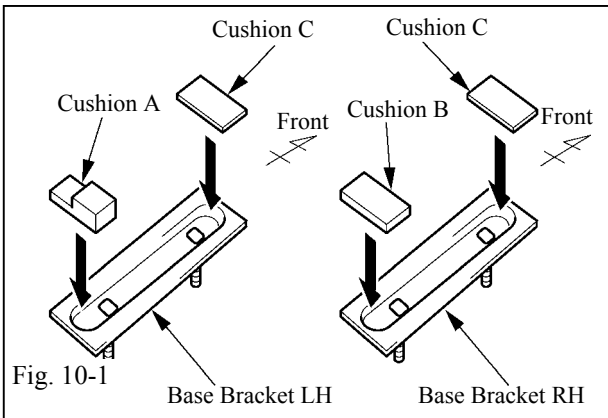

10. Install the Satellite Tuner.

- (a) Clean the bracket mounting surface with 3M™ Prep Solvent-70.
- (b) Place cushioned double-backed tape onto the bottom of each base bracket. (Fig. 10-1)
- (c) Peel back the carpet and felt.
- (d) Clean the bracket mounting surface on the floor with 3M™ Prep Solvent-70.
- (e) Position template A under the passenger's seat as shown with the arrow facing the front passenger side. (Fig. 10-2)
- (f) Remove the release paper from the double-backed tape, and then secure the base bracket over template A as shown.
- (g) Remove template A.

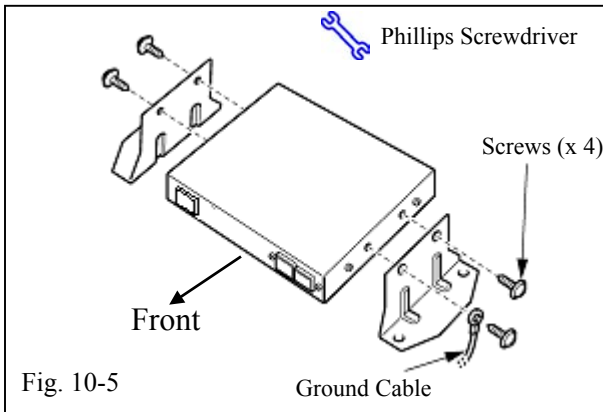
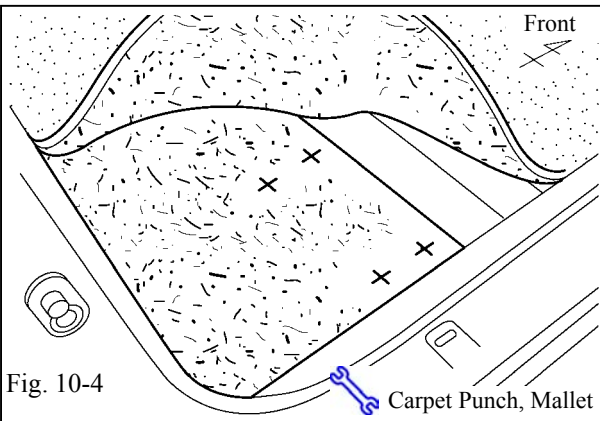
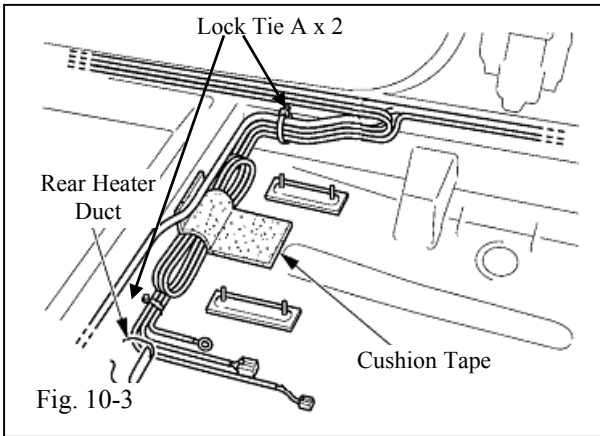

(h) Route the tuner cable, tuner ground cable and antenna cable together and secure the excess of the cables using cushion tape. (Fig. 10-3)

(1) Route the cables under the carpet and through the rear heater duct. The length of the cables over the carpet required are; 200 mm of the tuner ground cable, 300 mm of the tuner cable and 400 mm of the antenna cable.



(2) Verify the cables do not block the rear heater duct.



(i) Reinstall the carpet felt and verify the base bracket bolt positions. Transfer each bolt location onto the felt, then use the carpet punch and mallet. (Fig. 10-4)

(j) Pass the base bracket bolts through the felt.

(k) Repeat the same procedure (Step 10(i)) on the carpet, and then pass the base bracket bolts through the carpet.

(l) Install the satellite tuner brackets and ground cable onto the tuner. (Fig. 10-5)

NOTE: Start all machine screws by hand.

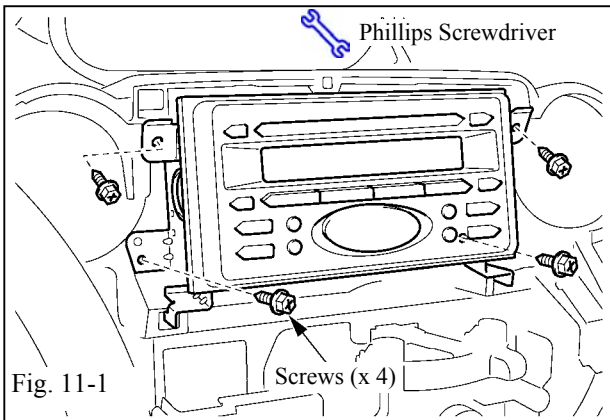
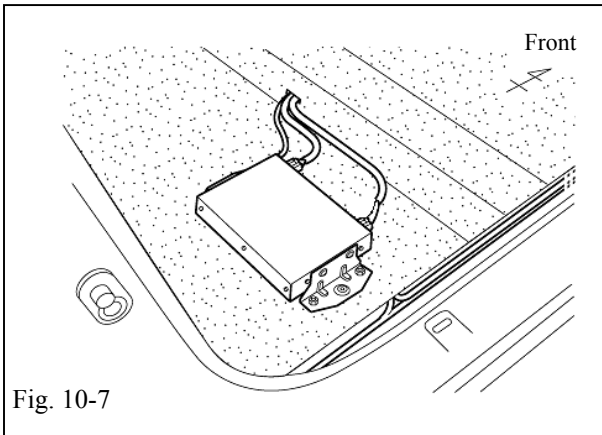
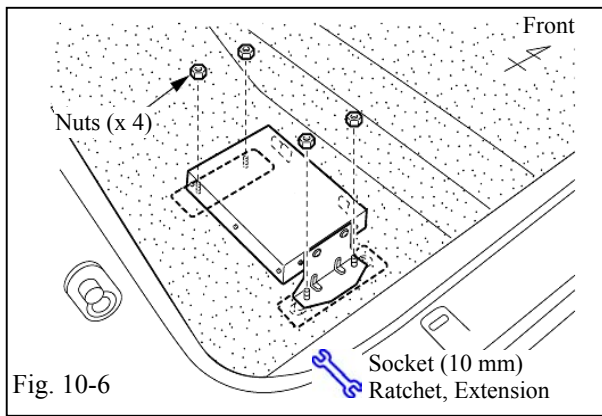

- (m) Secure the satellite tuner onto the base brackets so the connectors face toward the front of the vehicle. (Fig. 10-6)
- (n) Plug the tuner cable and antenna cable into the tuner. (Fig. 10-7)

11. Reinstall the Radio/Player Head Unit.

- (a) Connect the satellite tuner cable and the connectors removed in Step 2(b), into the rear of the head unit.
- (b) Insert head unit into opening and re-install the four (4) screws. (Fig. 11-1)

12. In Process Functional Test.

- (a) Temporarily reconnect battery negative cable.
- (b) Turn ignition key to ACC position.
- (c) Press the power button on the receiver/player head unit. Verify the backlighting illuminates.
- (d) Press and release the “SAT” button on the head unit.
 - (1) Verify that a satellite channel is received, or a “NO SIGNAL” message appears on the display.

NOTE: If “ANTENNA” appears (flashing) on the display – then the antenna cable is disconnected from the satellite tuner.

NOTE: If the head unit will not tune or go into satellite mode – then the tuner cable is disconnected from the satellite tuner.

- (e) Disconnect battery negative cable.

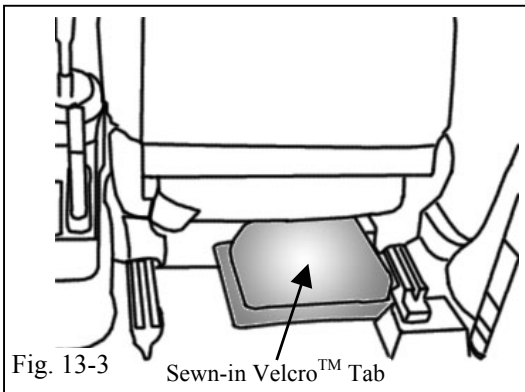
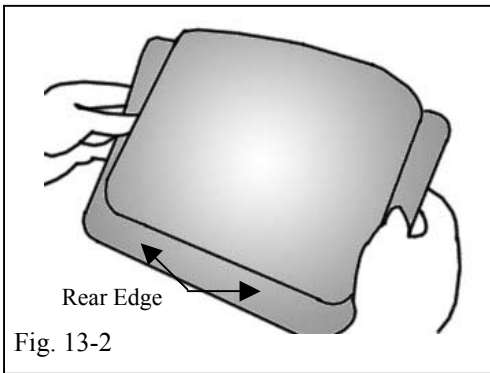
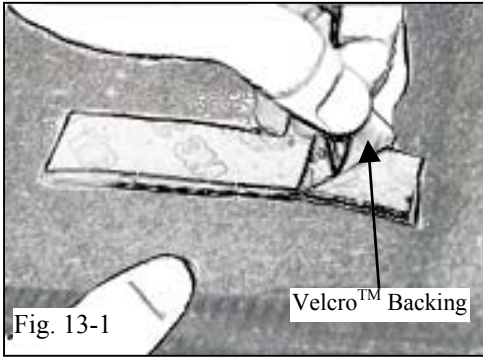

13. Installing Receiver Cover.

- (a) Remove the satellite receiver cover (P/N PT903-52040) from the poly bag.
- (b) Shape the cover so that it forms an open box shape with the Velcro™ facing down.

NOTE: Shipping and storage may have caused the shape to distort.

- (c) Peel the backing off the sewn-in Velcro™ strip inside the cover. (Fig. 13-1).
 - (1) Do not separate the Velcro™.
- (d) Clean the top of satellite receiver box with 3M™ Prep Solvent-70.
- (e) Align the rear edge of the cover with the rear edge of the satellite receiver. (Fig. 13-2).
- (f) Center cover to ensure satellite receiver mounting bolts are covered. Press Velcro™ to the floor carpet around the perimeter.
- (g) Press the sewn-in Velcro™ tab on the top underside of the cover firmly to the satellite receiver. (Fig. 13-3).

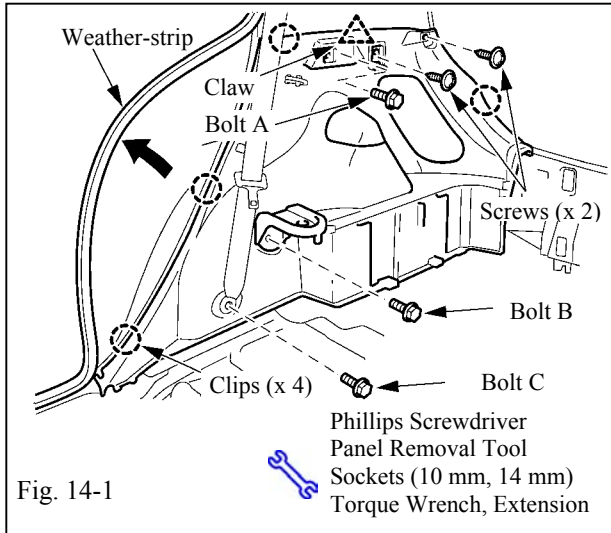

14. Complete the Reassembly of Vehicle.

- (a) Reconnect any disconnected connectors.
- (b) Re-install the front seat
 - (1) Reinstall the four (4) bolts loosely, then tighten them in the following order:
 - Rear inner bolt
 - Rear outer bolt
 - Front inner bolt
 - Front outer bolt
 - (2) Tighten bolts to 37 N•m (27 lbf•ft)
- (c) Re-install the passenger side deck trim side panel as follows (Fig. 14-1):
 - (1) Install the deck trim side panel, engage the clips and claws, and then re-install the weather-strip.
- (d) Re-install the rear seat belt anchor plate (bolt C –Fig. 13-1)
 - (1) Tighten bolt C to 42 N•m (31 lbf•ft)
- (e) Install the rear seatback hinge and bolt B.
 - (1) Tighten bolt B to 42 N•m (31 lbf•ft)
- (f) Install two (2) screws and bolt A.
- (g) Re-assemble the passenger front seat belt.
 - (1) Bolt and attach the passenger front seat belt anchor plate.
 - (2) Tighten the bolt to 42 N•m (31 lbf•ft)
 - (3) Attach the passenger front seat belt anchor cover.
- (h) Re-assemble the rear seat.
 - (1) Install the rear seat cushion, taking care that the retaining hooks are securely engaged.
- (i) Bolt and attach the right rear seatback.



- (1) Tighten bolts to 37 N•m (27 lbf•ft)
- (2) Fold up the seatback, and then fold down the cover over the bolts.



- (j) Verify the panels fit together properly with no uneven gaps between them.

15. Reconnect Battery Cable.

- (a) Reconnect the vehicle's negative battery cable. (Fig. 15-1)

- (1) Position the negative cable at original factory position.



- (2) Tighten the nut to 4.1 N•m (36 lbf•in).



- (3) Do not touch the positive terminal with any tool when replacing the cable.

- (b) Clean up and remove any trash.



- (c) Place the owner "XM Satellite Radio" brochure in the glove box.

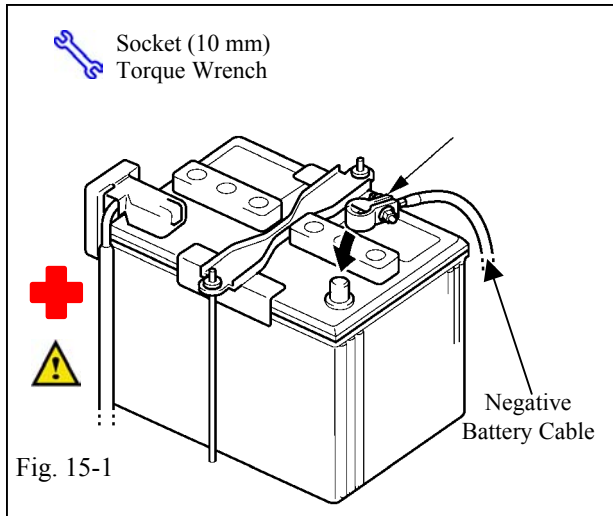

Checklist - these points **MUST** be checked to ensure a quality installation.

Check:

Look For:

Accessory Function Checks

- Satellite Radio Tuner.
- Receiver/player Assembly.

*Verify the proper operation of the Satellite Radio Tuner.

*Verify the proper operation of the Receiver/player Assembly

*(Refer to the receiver assembly and radio owner's manuals.)

Vehicle Function Checks

- Hazard switch.
- Passenger's seat belt reminder light.
- Removed seat.
- Proper operation of the removed seat lock mechanism.
- SRS warning light.
- HVAC (heating ventilation and air conditioning system).
- SSP function.

Proper operation of the hazard switch.

Proper operation of the passenger's seat belt reminder light.

Verify the removed seat is securely fastened.

Verify the proper operation of the removed seat lock mechanism.

Verify the SRS warning light illuminates for approximately 6 seconds with the ignition ON, and then goes out.

Proper operation of the air conditioning system.

Verify the radio SSP function is set to "xA" by pressing the "SSP" button on the head unit for 5 seconds. (If not, press the volume control and set to "xA".)