

**Part Number: PT347-35051 (Short Bed)**

**PT347-35052 (Long Bed)**

**NOTE:** Part number of this accessory may not be the same as the part number shown.

**Kit Contents**

Item #	Quantity Reqd.	Description
1	1	Bed Net
2	1	Installation Instructions
3	1	Hardware Bag

**Hardware Bag Contents**

Item #	Quantity Reqd.	Description
1	2	Tie-down Bracket

**Additional Items Required For Installation**

Item #	Quantity Reqd.	Description

**Conflicts**

--

**Recommended Tools**

<b>Personal &amp; Vehicle Protection</b>	<b>Notes</b>
None	
<b>Special Tools</b>	<b>Notes</b>
None	
<b>Installation Tools</b>	<b>Notes</b>
Wrench-10mm Hex Socket	
Torque Wrench	0 - 50 lbf.in
<b>Special Chemicals</b>	<b>Notes</b>
None	

**General Applicability**

--

**Recommended Sequence of Application**

Item #	Accessory

\*Mandatory

**Vehicle Service Parts** (may be required for reassembly)

Item #	Quantity Reqd.	Description

**Legend**



**STOP:** Damage to the vehicle may occur. Do not proceed until process has been complied with.



**OPERATOR SAFETY:** Use caution to avoid risk of injury.



**CAUTION:** A process that must be carefully observed in order to reduce the risk of damage to the accessory/vehicle and to ensure a quality installation.



**TOOLS & EQUIPMENT:** Used in Figures calls out the specific tools and equipment recommended for this process.



**REVISION MARK:** This mark highlights a change in installation with respect to previous issue.

Care must be taken when installing this accessory to ensure damage does not occur to the vehicle. The installation of this accessory should follow approved guidelines to ensure a quality installation.

These guidelines can be found in the "Accessory Installation Practices" document.

This document covers such items as:-

- Vehicle Protection (use of covers and blankets, cleaning chemicals, etc.).
- Safety (eye protection, rechecking torque procedure, etc.).
- Vehicle Disassembly/Reassembly (panel removal, part storage, etc.).
- Electrical Component Disassembly/Reassembly (battery disconnection, connector removal, etc.).

Please see your Toyota dealer for a copy of this document.

**1. Install Hardware.**

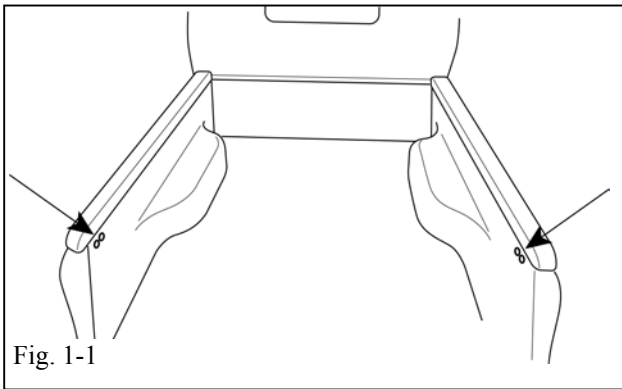

- (a) Locate the anchor points at the rear of the vehicle (Fig 1-1).
- (b) Using a 10 mm Hex socket wrench, remove both bolts on each side.
- (c) Position Tie Down Bracket, with the longer leg facing forward, over holes as shown, re-fasten bolts into holes over Tie Down Bracket (Fig. 1-2).
- (d) Tighten bolts to 5 N.m (3.7 lbf.ft, 44 lbf.in.)

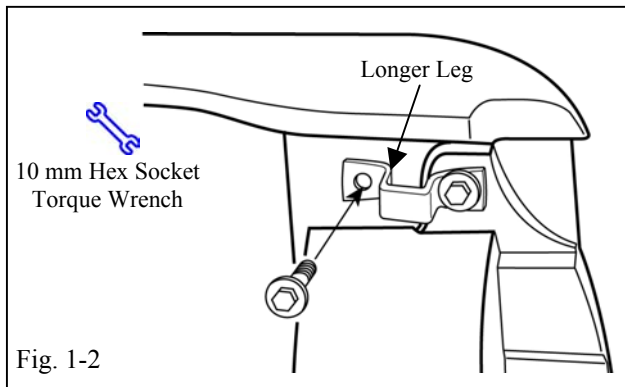

2. Install Net.

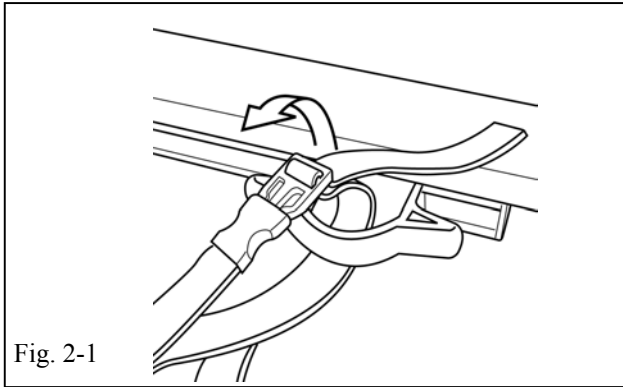

⚠ (a) Lay the net in the bed with the hooks near the tailgate. Starting at the front of the bed, insert the ends of the net through the front cleats and fasten the clips as shown (Fig. 2-1).

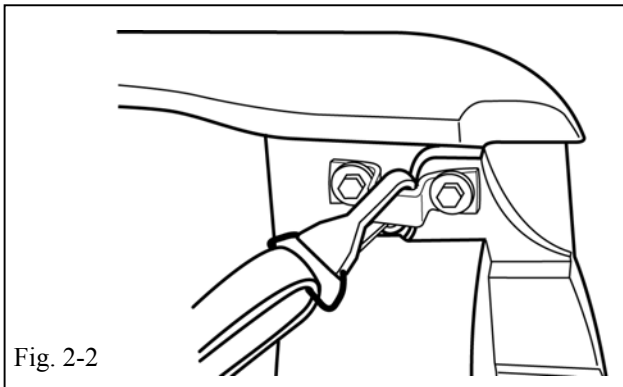

⚠ (b) Insert the ends of the net through the middle cleats and fasten the clips as shown (Fig. 2-1).

(c) Attach the hooks to the Tie Down Brackets at the rear of the bed as shown (Fig 2-2).

⚠ (d) Cinch the net taut at all six attachment locations as shown (Fig. 2-3).

⚠ (e) Confirm completed assembly (Fig. 2-4).

**NOTE:** Adjust cleats and straps as necessary to accommodate various size loads.

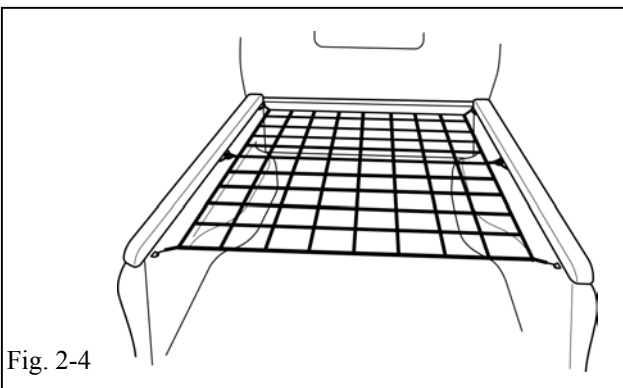
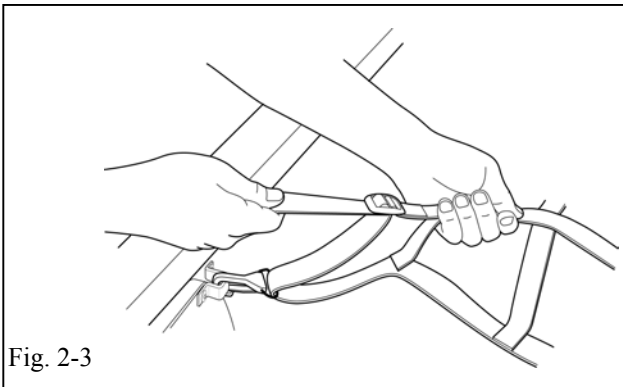

**TOYOTA TACOMA 2005 - CARGO BED NET**  
Checklist - these points **MUST** be checked to ensure a quality installation.

---

Check:

Accessory Function Checks

Confirm that the net is attached properly to the anchor points in the vehicle.

  Confirm that the hardware is attached properly to the vehicle.

Look For:

Make sure net straps have been inserted from the underside of the cleat and the snap clips have been securely fastened. Make sure hooks have been fastened securely to the Tie Down Brackets.

Make sure bolts have been fastened to the vehicle over the Tie Down Brackets. Make sure the bolts are fastened tightly over the Tie Down Brackets.