

Part Number: PT248-52081

Kit Contents

Item #	Quantity Reqd.	Description
1	1	Cargo Liner
2	1	Instruction sheet

Hardware Bag Contents

Item #	Quantity Reqd.	Description
1		
2		

Additional Items Required For Installation

Item #	Quantity Reqd.	Description
1		
2		

Conflicts

--

Recommended Tools

Personal & Vehicle Protection	Notes
Blanket	
Special Tools	Notes
Installation Tools	Notes
Special Chemicals	Notes
None	

General Applicability

Note: All xD models

Recommended Sequence of Application

Item #	Accessory
1	
2	
3	





*Mandatory

NOTE: Part number of this accessory may not be the same as the part number shown.

Vehicle Service Parts (may be required for reassembly)

Item #	Quantity Reqd.	Description
1		
2		
3		

Legend

	STOP: Damage to the vehicle may occur. Do not proceed until process has been complied with.
	OPERATOR SAFETY: Use caution to avoid risk of injury.
	CAUTION: A process that must be carefully observed in order to reduce the risk of damage to the accessory/vehicle and to ensure a quality installation.
	TOOLS & EQUIPMENT: Used in Figures calls out the specific tools and equipment recommended for this process.

Care must be taken when installing this accessory to ensure damage does not occur to the vehicle. The installation of this accessory should follow approved guidelines to ensure a quality installation.

These guidelines can be found in the "Accessory Installation Practices" document.

This document covers such items as:-

- Vehicle Protection (use of covers and blankets, cleaning chemicals, etc.).
- Vehicle Disassembly/Reassembly (panel removal, part storage, etc.).

Please see your Toyota dealer for a copy of this document.

1. Preparation

- (a) Open carton and inspect kit for content and damage.

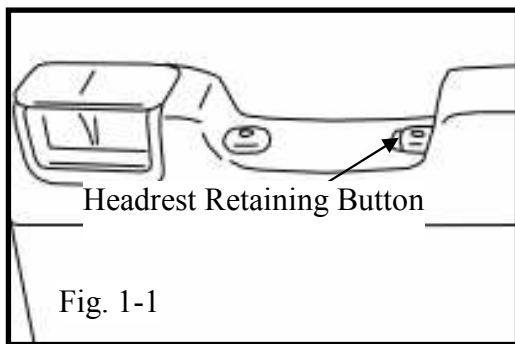

2. Remove Headrests.



- (a) Remove the three headrests by pushing in the headrest retaining buttons and pulling the headrests off (Fig. 1-1).
- (b) Store the three (3) headrests.

3. Install Cargo Liner

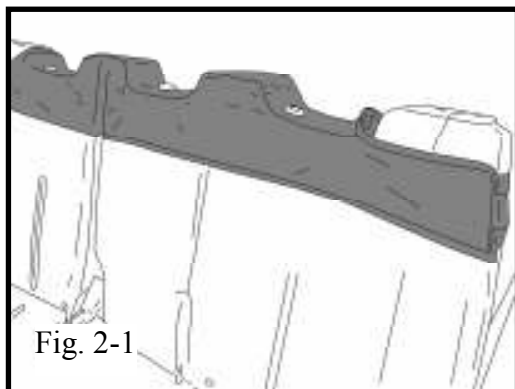

- (a) Tilt rear seatback forward by pulling the release lever on top of seatback.
- (b) Place cargo liner over seatback (Fig. 2-1).



- (c) Pull cargo liner tight over the seatbacks. Attach the Velcro® strips on the outer side of the seatback (Fig. 2-2).
- (d) Align cover with seatback edges.
- (e) Pull cargo liner snug until flush with seatback.

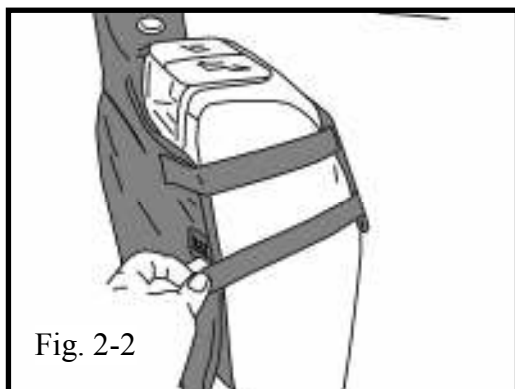

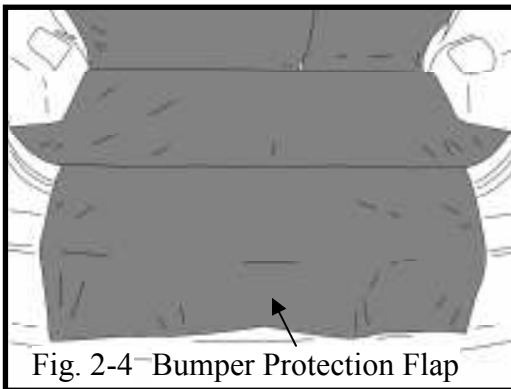
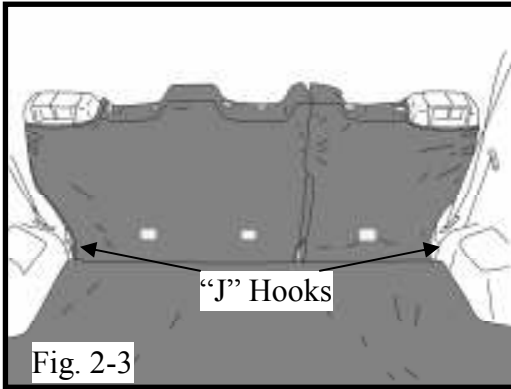

- (f) Re-install the three (3) headrests.
- (g) Lower seatback flat
- (h) Open rear hatch door.
- (i) Align cargo liner with seatback contours and engage “J” hooks along seat back edges. (Fig. 2-3)
- (j) Pull cargo liner to rear door opening. Bumper protection flap will extend out rear door when loading cargo. (Fig. 2-4)



- (k) Attach Velcro® fasteners to the (2) cargo tie downs on the floor in the rear of the vehicle. (Fig. 2-5)

- (l) Raise seatback.



- (m) Tuck excess material in opening between seatback and cargo floor when seatbacks are raised with the cargo liner installed.

- (n) Mate the Velcro® fasteners on each side of the seat split.

- (o) Close rear hatch door.

4. Installation Instructions.



- (a) Place installation instructions in glove box for future customer reference.

Checklist - these points **MUST** be checked to ensure a quality installation.

Check:

- Check installation instructions
- Check security of headrests
- Check security of rear seatback

Look For:

Check installation instructions are placed in glove box.

Center seat belt buckle is secure.

Center headrests are secure.

Center rear seatback is locked into position and secure.