

Part Number: PT374-47040

Section I - Installation Preparation

Kit Contents

Item #	Quantity Req'd.	Description
1	1	AD Mirror Assembly with HomeLink ^R
2	1	Hardware Bag
3	1	Installation Manual

Hardware Bag Contents

Item #	Quantity Req'd.	Description
1	2	T-tap Connector: Red 3M
2	1	Wire Cover
3	1	EC Wire Harness
4	6	Foam Tape
5	10	Wire Ties
6	1	Operation Instruction Card

Additional Items Required For Installation

Item #	Quantity Req'd.	Description
1		

Conflicts

Note: Models with Side Air Curtain

Recommended Tools

Safety Tools	
Vehicle Protection	Blankets
Special Tools	
None	
Installation Tools	
Screwdriver	Phillips #2
Ratchet	
Socket	10 mm
Pliers	Needle Nose
Nylon Panel Removal Tool	e.g. Panel Pry Tool #1 Toyota SST # 00002-06001-01
Slotted Nylon Removal Tool	*See Note below.
Torque Wrench (2)	0-60 lbf-in., & 0-10 lbf-ft.
Torx Head Driver	T20
Side Cutters	
Dark Towel or Cloth	For Testing
Safety Gloves	
Electrical Tape	

*NOTE: A suitable tool can be obtained from:-

Plastic Factory

(310) 532-8850

Issue: A 10/10/03

Special Chemicals	
Cleaner	3M TM Prep Solvent-70, or Household Windex

General Applicability





--

Recommended Sequence of Application

Item #	Accessory	
1	Audio	P6
2	EC Mirror	N1
3	TVIP	V2 or V5

*Mandatory

Legend

	STOP: Damage to the vehicle may occur. Do not proceed until process has been complied with.
	OPERATOR SAFETY: Use caution to avoid risk of injury.
	CRITICAL PROCESS: Proceed with caution to ensure a quality installation.
	GENERAL PROCESS: This highlights specific processes to ensure a quality installation.
	TOOLS & EQUIPMENT: Calls out the specific tools and equipment recommended for this process.

Section II - Installation Procedure

NOTES:

Removed Parts:-

 Place all removed parts on a protected surface.

Connectors:-

 When disconnecting connectors, do not pull on the wires; pull on the connectors.

Wire Ties:-

 When using wire ties to secure harness, clip the wire ties after securing them.

A. Vehicle Disassembly.

1. Lift up the luggage center box cover (rear floor board no. 2). (Fig. A-1)

-  i. Cover the rear trunk edge and bumper with blanket before starting.
- ii. Release the lock mechanism from the lock to the unlock position.

2. Lift up the center luggage box (deck floor box rear). (Fig. A-2)

3. Remove the right (passenger) side battery cover (rear floor board no. 3) including vertical trim cover by separating the four (4) claw fittings. (Fig. A-3)

4. Remove the negative battery cable of the auxiliary battery. (Fig. A-4)

 i. Do not touch the positive terminal with any tool when removing the cable.

5.

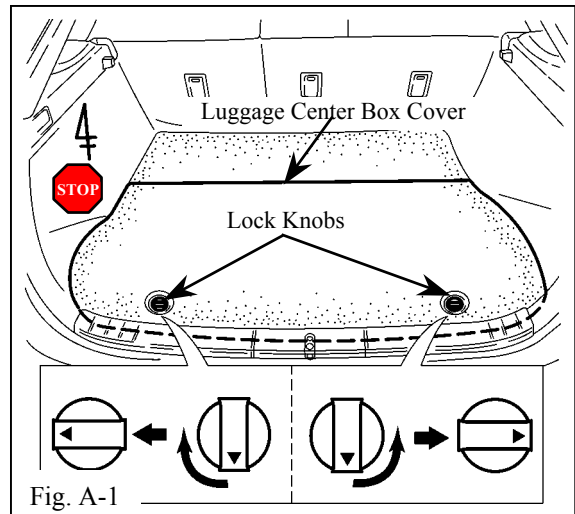

Fig. A-1

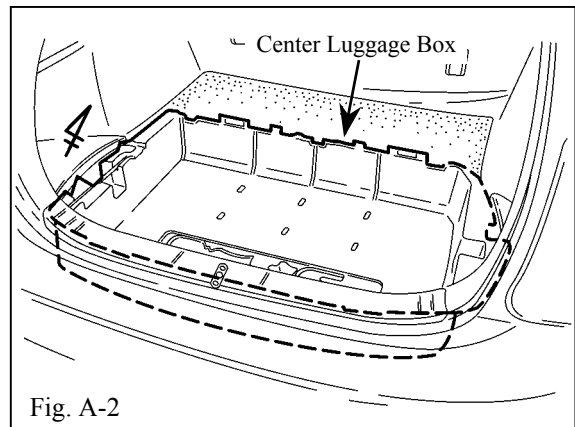

Fig. A-2

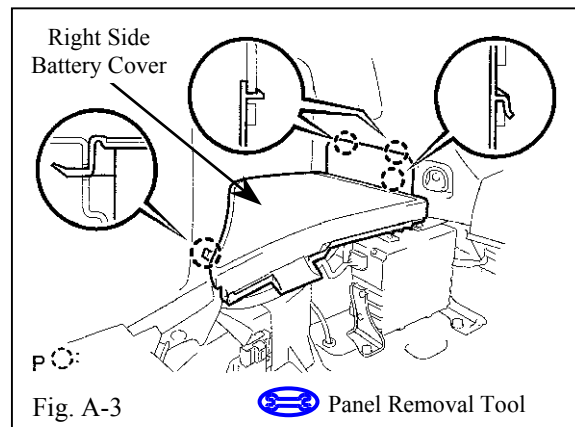

Fig. A-3

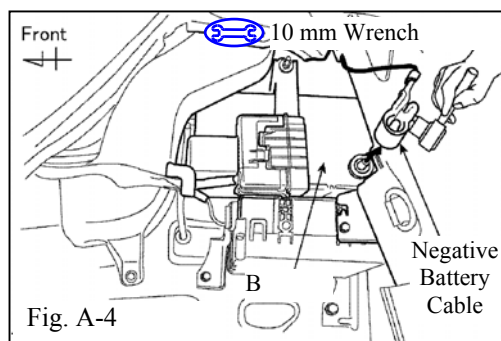

Fig. A-4

Remove the driver side vent panel by releasing the eight (8) panel clips/locator pins. (Fig. A-5)

6. Remove the lower dash cover. (Fig. A-6)
 - i. Remove two (2) screws securing the lower dash cover.
 - ii. Remove the hood release cable from the hood release latch
 - iii. Release the five (5) panel clips and two (2) locator pins.
 - iv. Remove the connectors.



7. Be careful when handling the lower dash cover during removal. The insulators in the lower dash cover break easily. (Fig. A-7)

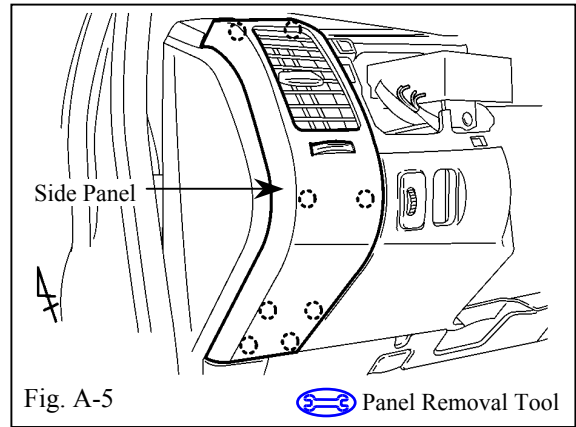

Fig. A-5

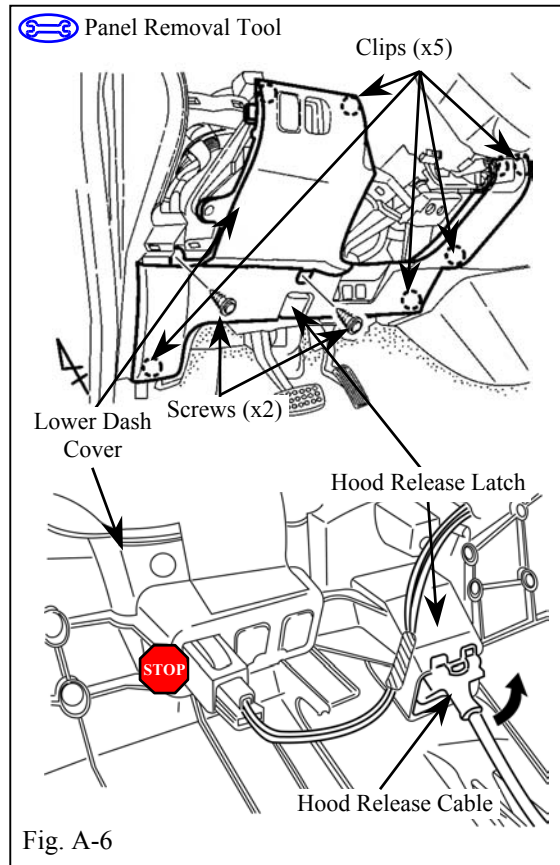

Fig. A-6

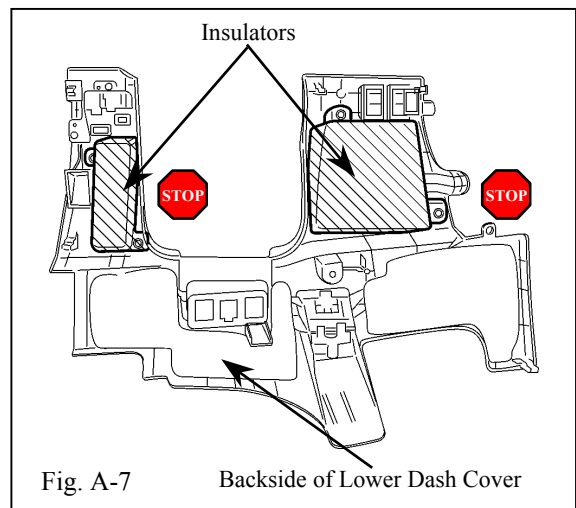

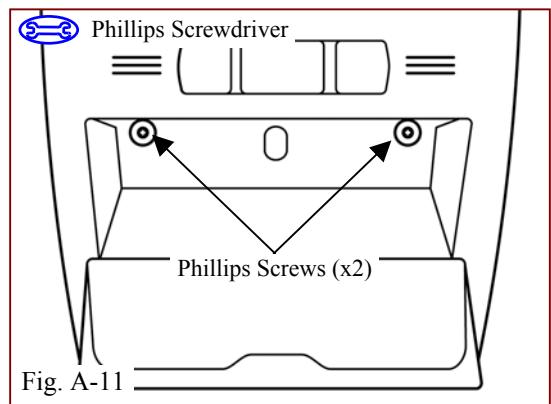
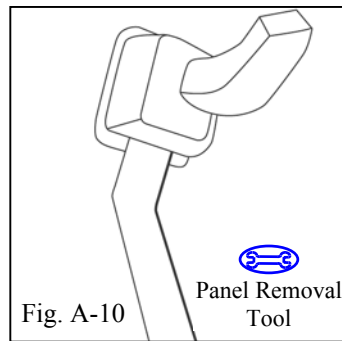
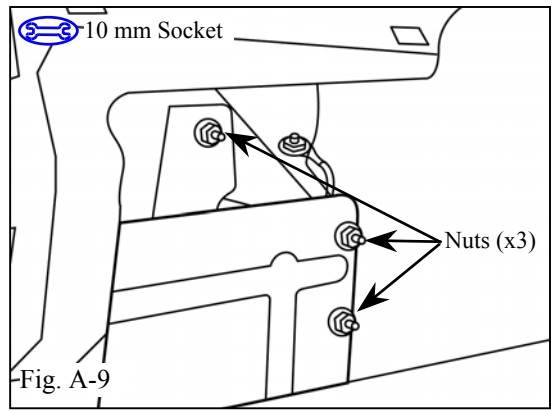
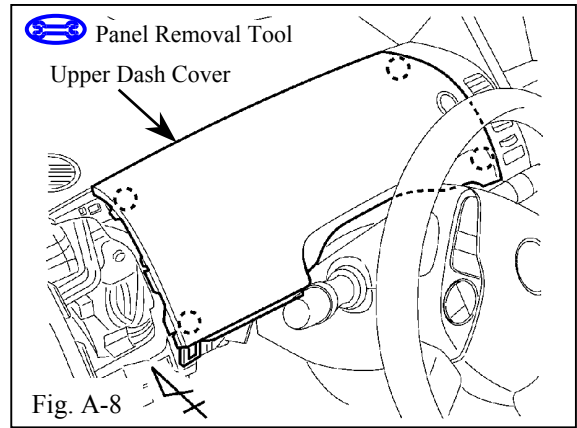





Fig. A-7

8. Remove upper dash cover. (Fig. A-8)
 - i. Carefully insert removal tool to disengage clips to remove panel.
 - ii. Pull upper dash cover upwards and rearward to remove.
 - iii. Disconnect the connector from the ignition Start/Stop push button switch.
9. Remove metal plate covering junction block. (Fig. A-9)
 - iv. Remove three (3) nuts, using a 10 mm socket.
-  10. Remove OE mirror and discard.
 - v. Insert tip of panel removal tool into mirror base to release mirror from button. (Fig. A-10)
11. Open sunglass holder lid in overhead console.
 - vi. Remove two (2) Phillips screws. (Fig. A-11)
 -  vii. Do not mix these screws with other screws from lower dash cover.



12. Using a nylon removal tool, insert tool at rear edge of overhead console bezel and carefully pry down. (Fig. A-12)
13. With hands, carefully pull down the front edge of console bezel to release the clips holding the console. (Fig. A-13)
14. Disconnect connector from the overhead console. (Fig. A-14)

B. Remove Sun Visor and Visor Clips.

-  1. Using a slotted panel removal tool, loosen both driver and passenger side sun visor clips by rotating clips 90 degrees counter clockwise. (Fig. B-1)
 -  i. Carefully pull clip with headliner down, taking care not to damage clip. It is not necessary to remove clip from the headliner.
 -  ii. Rotating clip clockwise or more than 90° will cause damage to clip when trying to remove it.

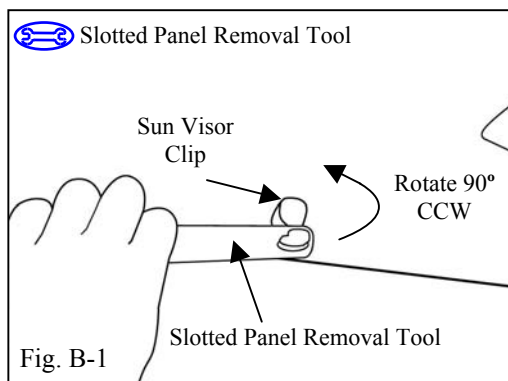
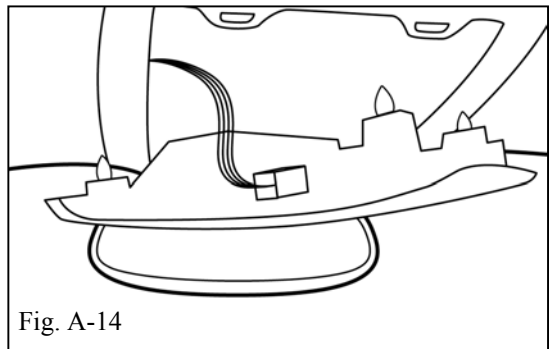
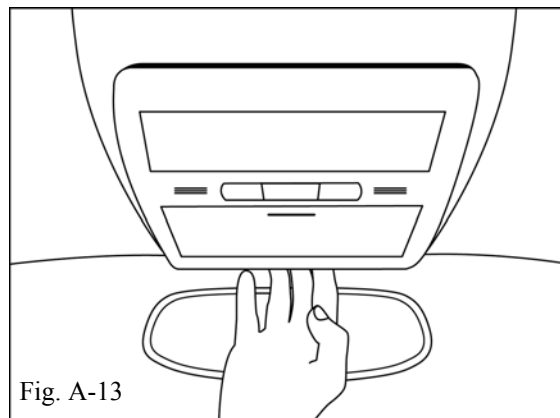
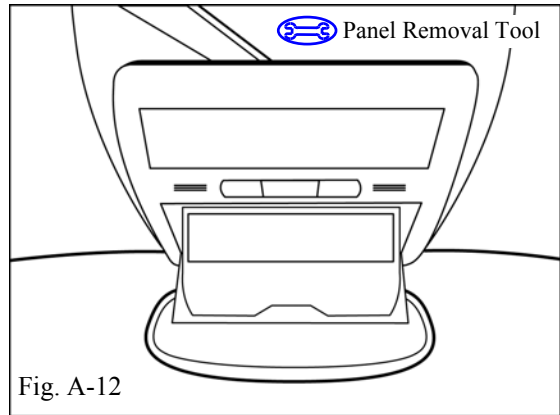

2. Remove two (2) screws from the driver side sun visor base. (Fig. B-2)
 - i. Remove sun visor.

C. Remove Vehicle Trim Components.

1. With a nylon panel removal tool, carefully pry away the top of A-pillar and remove. (Fig. C-1)
 - i. Be careful not to scratch pillar.
 - ii. Detach retaining plastic tab by twisting and aligning with slot. (Fig. C-2)
 - iii. Remove A-pillar trim.



D. Mirror Installation.

1. Slide the Electrochromic HomeLink^R mirror onto the mounting button on the windshield. (Fig. D-1)
2. Tighten the screw on the mirror mounting bracket. (Fig. D-2)
 - i. Tighten to 15.5 lbf-in.
3. Plug the wire harness 10-pin connector into the back of the mirror.
 - i. Route the mirror wire harness into the groove of the windshield wire cover.
 - ii. Attach the windshield wire cover to the mirror mounting bracket.

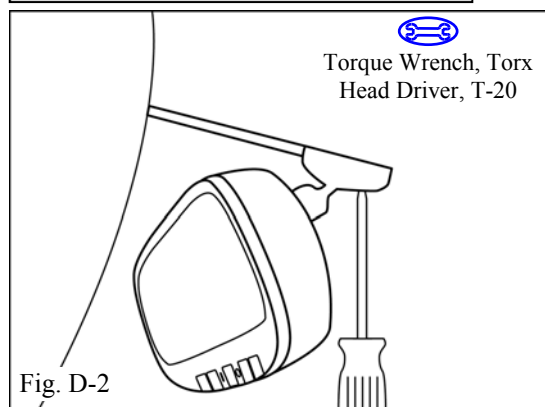
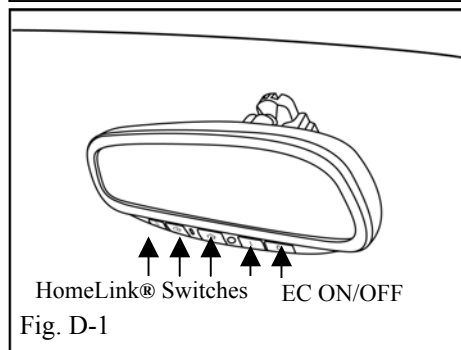
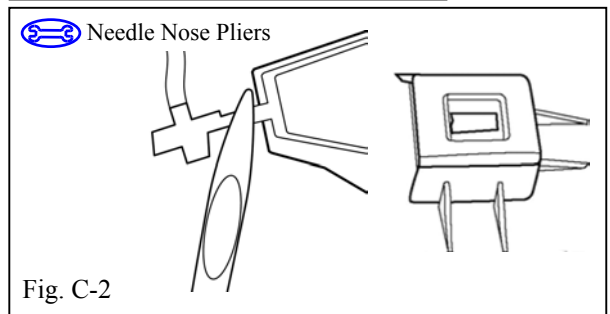
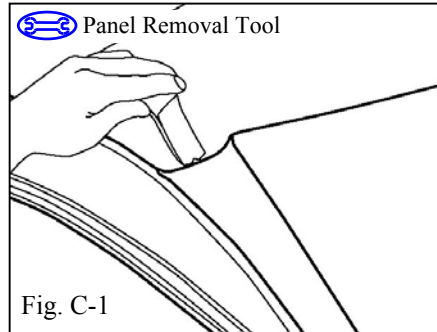
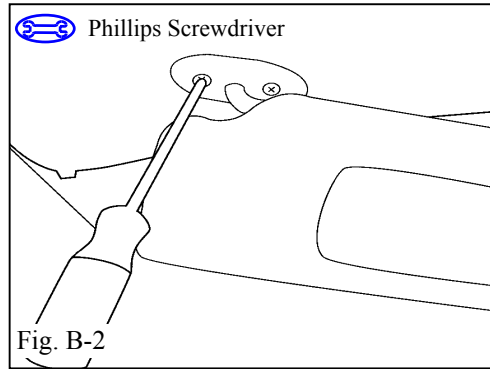



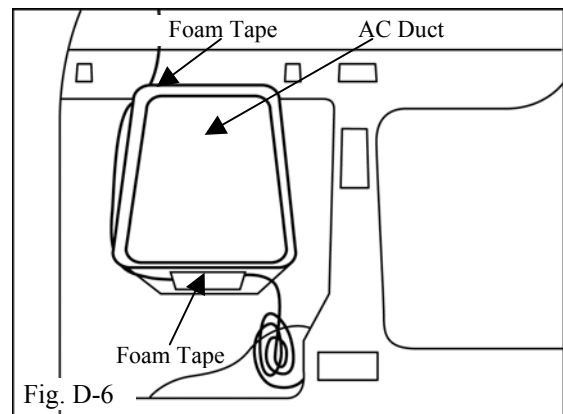
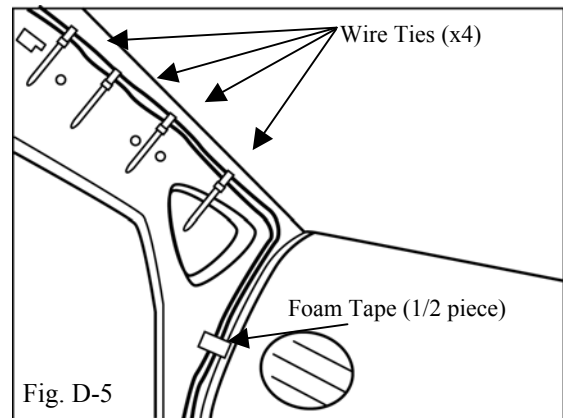
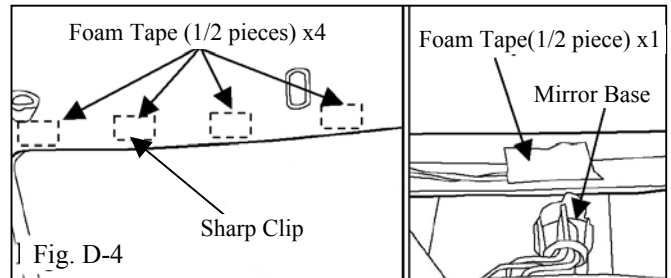
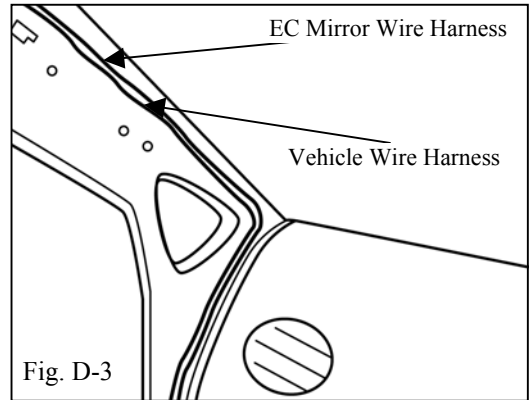

4. Slide the wire cover firmly under the headliner.
 - i. Be careful not to bend headliner.
5. Route the mirror wire harness into the headliner.
 - i. Place wire under the padding and down the A-pillar alongside the OEM wire harness. (Fig. D-3)
 - 

ii. Wire harness must allow mirror to experience full range of movement (turn full left and full right) with tension relief.
6. Cut three (3) pieces of foam tape in half.
 - 

i. Apply foam tape to headliner (in five (5) places) as shown. (Fig. D-4)
 - ii. Be sure to place foam tape under sharp metal clip when taping to headliner.
7. Loosely secure the mirror wire harness to the OEM wire harness with four (4) wire ties along the A-pillar and foam tape on the A/C duct as shown. (Fig. D-5)
 - i. Route harness forward of I/P brace, to J/B.
 - ii. Cut foam tape into two (2) pieces; use one (1) piece to secure harness to top of A/C duct and the other piece to the bottom of the A/C duct. (Fig. D-6)



8. Locate the black/white wire (ACC) and the black wire (B+) at the end of the mirror wire harness and pull both apart from the ground wire for a distance of 8". (Fig. D-7)
 - i. Wrap the black/white wire (ACC) and the black wire (B+) with electrical tape.
9. Locate the 36-pin white connector on the front side of the I/P junction block. (Fig. D-8)
10. Locate the violet wire in pin #19 from the connector. (Fig. D-8)
11. Apply the Red T-tap connector to the violet wire about one inch from connector with pliers. (Fig. D-8)
 -  i. Make sure T-tap halves are snapped together and secure.
12. Plug the red connector of the black/white wire from the mirror wire harness into the T-tap.
 -  i. Make sure the spade terminal is properly inserted into T-tap to make electrical contact.
13. Locate the 6-pin white connector on the IP junction block. (Fig. D-9)
14. Locate the Red wire in pin #5 of the connector. (Fig. D-9)
15. Apply the Red T-tap connector to the red wire about one inch from connector with pliers. (Fig. D-9)
 -  i. Make sure T-tap halves are snapped together and secure.
16. Plug the red connector of the black wire from the mirror wire harness into the T-tap.
 -  i. Make sure the spade terminal is properly inserted into T-tap to make electrical contact.

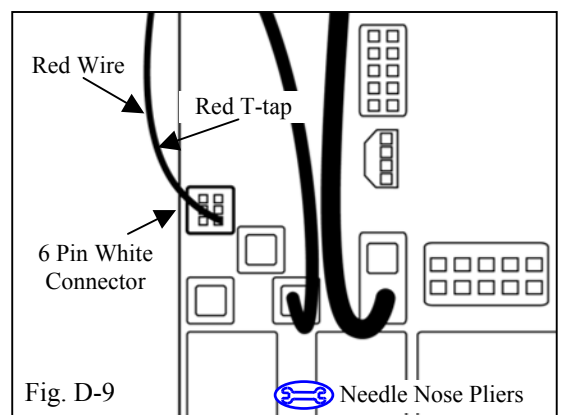
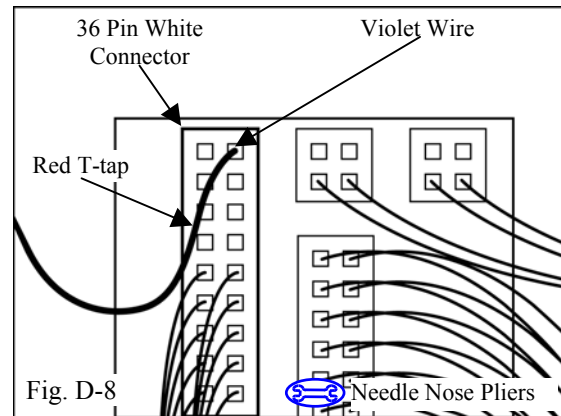
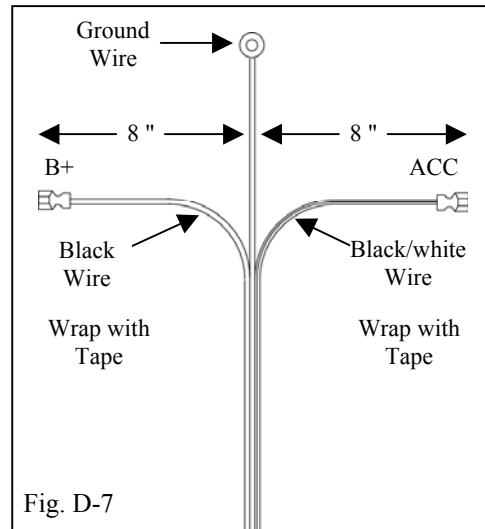

17. Locate the vehicle ground bolt on the IP brace.

- ➔ i. Secure ground wire to OEM harness with one (1) wire tie. (Fig. D-10)

18. Using a 10 mm socket and ratchet, attach the ground lug of the mirror wire harness to the vehicle ground bolt. (Fig. D-10)

- ➔ i. Make sure that the bolt is secure.

19. Bundle excess mirror wire harness to the vehicle's main harness and secure excess with wire ties. (Fig. D-11, D-12, D-13)

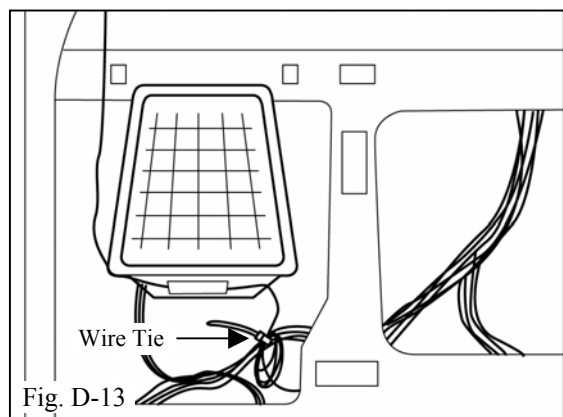
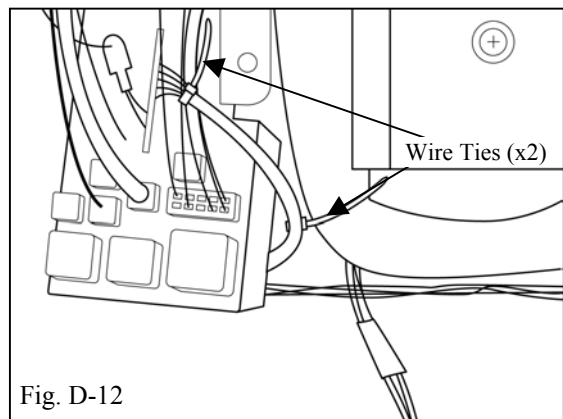
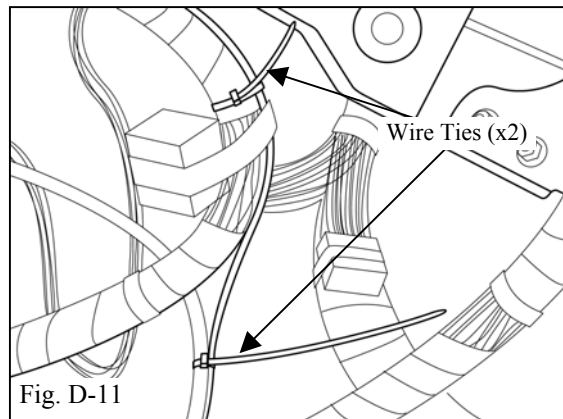
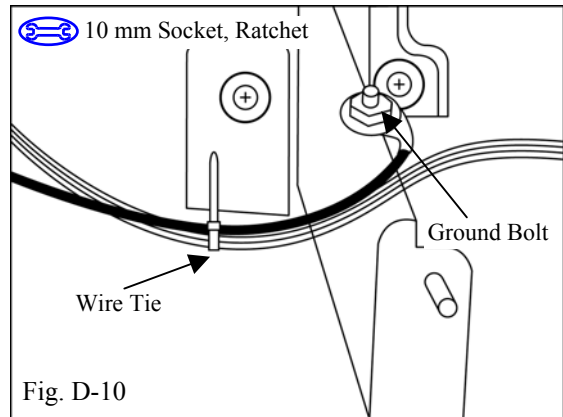

E. Partial Re-assembly.

1. Reassemble metal plate covering the junction block removed in Step A. 9..



- i. Tighten the three (3) nuts.

2. Reinstall the upper dash cover removed in Step A. 8..



- i. Reconnect electrical connector to the ignition Start/Stop push button switch.



- ii. Be sure to use correct Phillips screws.

3. Reinstall lower dash cover removed in Step A. 6..



- i. Reconnect electrical connectors.

F. Testing.

1. Reconnect the vehicle's negative battery cable. (Fig. F-1)



- i. Position the negative terminal at an angle of 90° to the battery as shown.



- ii. Tighten the nut to 4.1 N-m (36 lbf-in).



- iii. Do not touch the positive terminal with any tool when replacing the cable.

2. Insert the remote key or the smart key (as appropriate) into the key slot.

3. With the vehicle in a fairly well-lit area, perform the following:

4. Auto Dimming Feature:

- i. To make sure the auto-dimming feature is on; verify that the green LED to the left of the center switch is on. If it is not on, push the 'I' button to turn it on. (Fig. F-2)

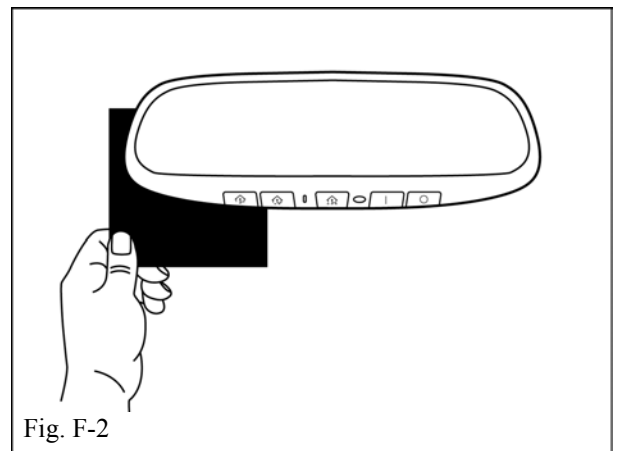
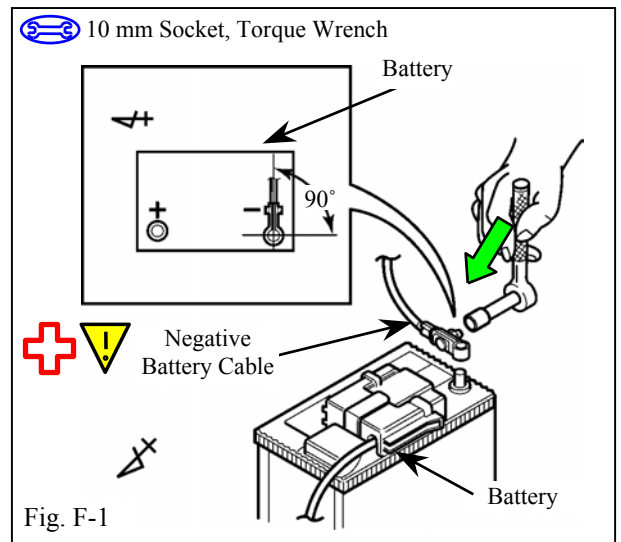

- ii. Cover (using dark cloth or towel) the forward-looking photocell located above wire harness connection on back of mirror.
- iii. After a few seconds, the mirror will begin to darken (the time may vary with ambient light levels).
- iv. Remove the cover from the forward photocell and mirror will begin to clear.

5. HomeLink^R:



- i. Push in HomeLink^R switches, one at a time. Verify that the LED Indicator light is red when each switch is pushed.
- ii. Remove the remote key or the smart key (as appropriate) from the key slot.
- iii. Push in HomeLink^R switches, one at a time. Verify that the LED Indicator light is red when each switch is pushed.
- iv. The owner of the vehicle will need to program HomeLink^R. See the Prius Owner's Manual or www.homelink.com.

G. Final Assembly.

- 1. Reinstall driver's side A-pillar garnish.
- 2. Reinstall sun visor and sun visor clip.
- 3. Reinstall overhead console.



- i. Be sure to use correct Phillips screws.

- 4. Reinstall battery cover and center luggage box cover.



- 5. Place the operation instruction card in the vehicle glove box.



- 6. Remove fingerprints, smudges, dirt, etc. from mirror glass with 3MTM Prep Solvent-70 or Household Windex.

-  i. When cleaning with 3M™ Prep Solvent-70 follow the manufacturer's directions. Do not allow cleaner to air dry.

-  7. Verify each reinstalled component for proper fit and function.



Section III - Functional Verifications

Check: _____

Accessory Function Checks

Vehicle should be in a fairly well lit area.

- Insert the remote key or the smart key (as appropriate) into the key slot.

Auto-dimming feature:

- Cover the forward-looking photo cell (located below the wire harness connection on the back of the mirror.)

Mirror Clears:

- Remove cover from the photocell.

Homelink^R feature:

- Push in HomeLink^R switches with remote key or the smart key (as appropriate) in AND out of the key slot.
- Push the 'Mirror' switch a second time and hold for 3 seconds.

Look For: _____

Verify green LED, to the right of the switch, is on. If it is not on, push the 'Mirror' button to turn it on.

Verify mirror darkens.

Mirror returns to clear state.

Verify LED indicators turns red.

Verify the visual display turns off.

Vehicle Function Checks

- Map lamps/Dome lamp with door closed.
- Hood Release.
- Traction light.
- Instrument Panel Light Dimmer.

Map lamps should turn off.

Verify that hood latch releases.

Light goes on/off by pressing switch.

Verify IP lights dim.