

Part Number: PTR07-47100

Kit Contents

Item #	Quantity Req'd.	Description
1	2	Front Spring
2	2	Rear Spring
3	2	Nut
4	1	Instructions

Hardware Bag Contents

Item #	Quantity Req'd.	Description
1		
2		
3		

Additional Items Required For Installation

Item #	Quantity Req'd.	Description
1	PTR07-47100-AA	Spring Spacer (4 required) (PPO Only)
2	Nylon Tie	8-1/2" L, 0.30" W, 120# Tensile Strength (PPO Only)
3		

Conflicts

--

Recommended Tools

Personal & Vehicle Protection	Notes
Fender Covers	2
Safety Glasses	
Special Tools	Notes
Spring Compressor	
Tall Jack Stand	
Edge Trim	
Installation Tools	Notes
Torque Wrench	3/8" & 1/2" Drive
Sockets, 3/8" Drive	10, 14, 17mm
Sockets, 1/2" Drive	17, 19, 21, 22mm
1/2" Impact Gun	Only for removing fasteners
3/8" Air Ratchet	Only for removing fasteners
Nylon Pry Tool	
Special Chemicals	Notes

General Applicability

Prius Sedan

Recommended Sequence of Application

Item #	Accessory
1	PLUS Springs
2	PLUS Rear Sway Bar
3	

*Mandatory

Vehicle Service Parts (may be required for reassembly)

Item #	Quantity Req'd.	Description
1	2	90177-14005 Nut, Front Shock
2		
3		

Legend

 **STOP:** Damage to the vehicle may occur. Do not proceed until process has been complied with.

 **OPERATOR SAFETY:** Use caution to avoid risk of injury.

 **CAUTION:** A process that must be carefully observed in order to reduce the risk of damage to the accessory/vehicle and to ensure a quality installation.

 **TOOLS & EQUIPMENT:** Used in Figures calls out the specific tools and equipment recommended for this process.

 **REVISION MARK:** This mark highlights a change in installation with respect to previous issue.

 **SAFETY TORQUE:** This mark indicates that torque is related to safety.



Care must be taken when installing this accessory to ensure damage does not occur to the vehicle. The installation of this accessory should follow approved guidelines to ensure a quality installation.

These guidelines can be found in the "Accessory Installation Practices" document.

This document covers such items as:-

- Vehicle Protection (use of covers and blankets, cleaning chemicals, etc.).
- Safety (eye protection, rechecking torque procedure, etc.).
- Vehicle Disassembly/Reassembly (panel removal, part storage, etc.).
- Electrical Component Disassembly/Reassembly (battery disconnection, connector removal, etc.).

Please see your Toyota dealer for a copy of this document.

1. Remove the Cowl.



- (a) Install a brake jack tool.
- (b) Raise the hood.
- (c) Place fender covers over fenders.
- (d) Remove the windshield wiper arms.

- (1) Remove the wiper arm head caps with a nylon pry tool (Fig. 1-1).

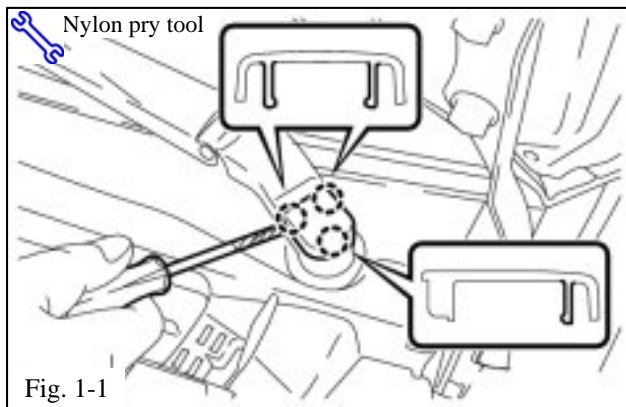

Fig. 1-1

- (2) Remove the 2 nuts and pull the wiper arms off of the wiper drive studs (Fig. 1-2).

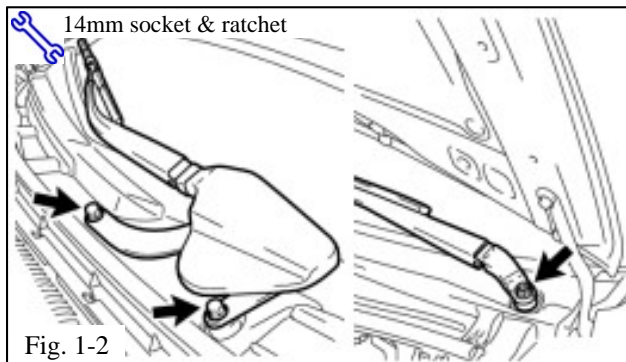

Fig. 1-2

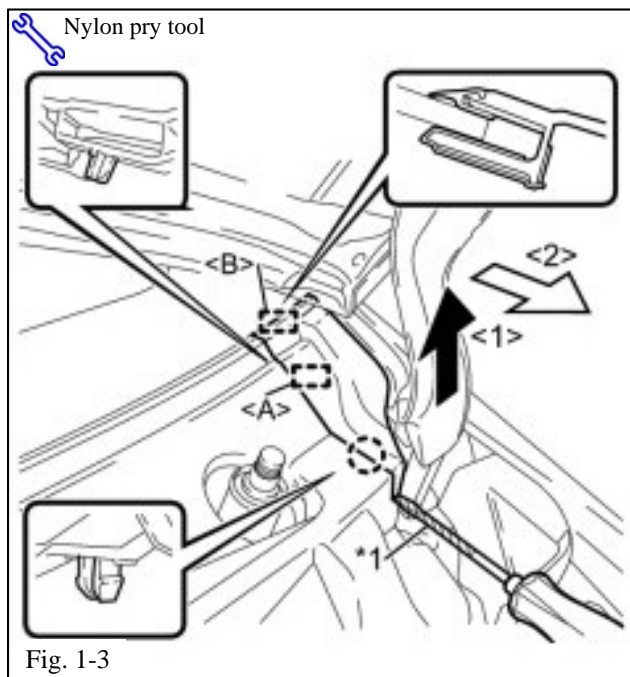

Fig. 1-3

(e) Remove the cowl side ventilator sub-assemblies.

- (1) Use a pry tool to disengage the claw and guide (<A> Fig. 1-3).
- (2) Disengage the guide and remove the cowl side ventilator sub-assembly LH (Fig. 1-3).

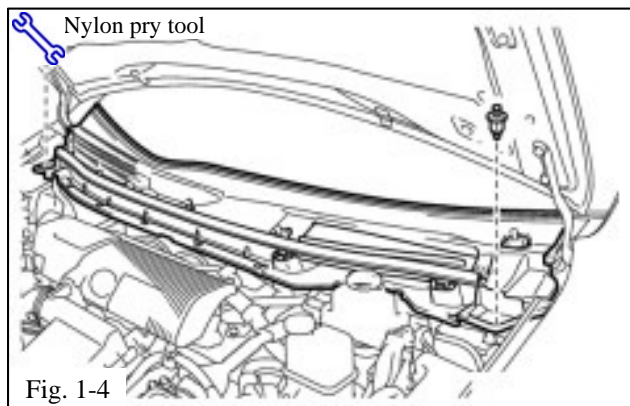
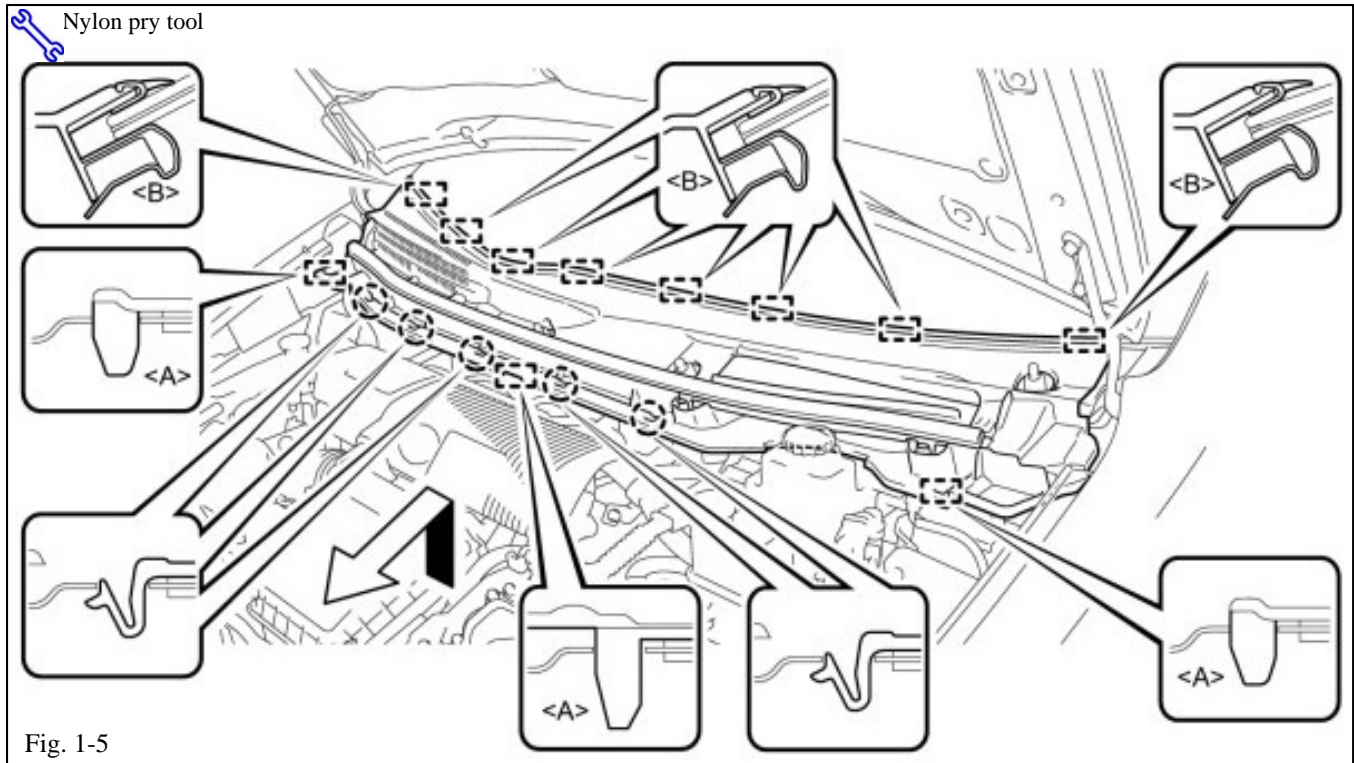

Fig. 1-4

(f) Remove the cowl cover.

- (1) Remove the 2 clips (Fig. 1-4).

- (2) Disengage the 5 claws and 3 guides (<A> Fig. 1-5).
- (3) Pull out the cowl top ventilator louver sub-assembly (Fig. 1-5).



-  (g) Protect the lower edge of the windshield with tape or edge trim. 

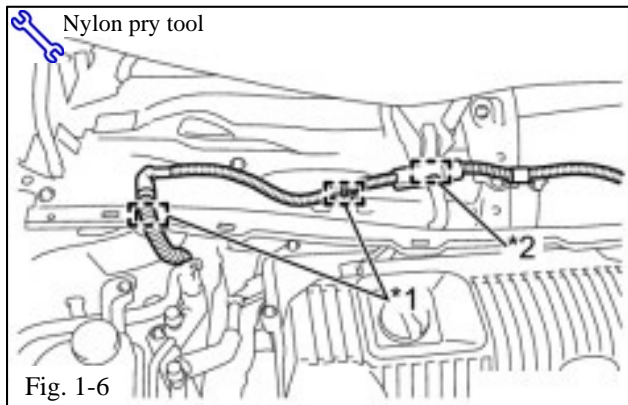

- (h) Use a pry tool to remove the two wire harness plastic fasteners (*1 Fig. 1-6).

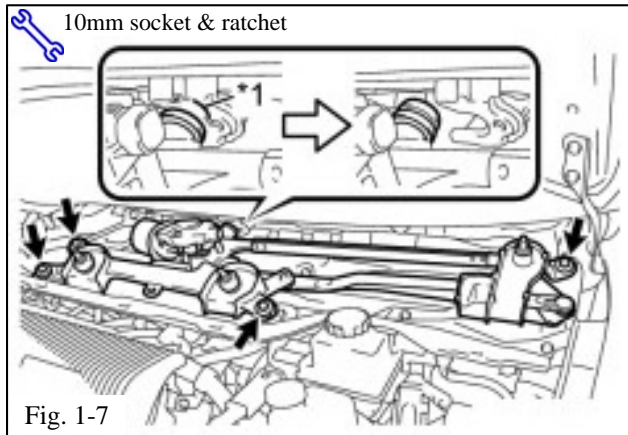

- (i) Remove the wiper link / motor assembly.
 - (1) Remove the 4 screws (Fig. 1-7).
 - (2) Slide the assembly to the right to disengage the rubber locating grommet (Fig. 1-7).
- (j) Place the wiper motor assembly on a protective pad or blanket on top of the engine.
- (k) Remove the cowl pan.

2. Remove the Front Strut Assembly.

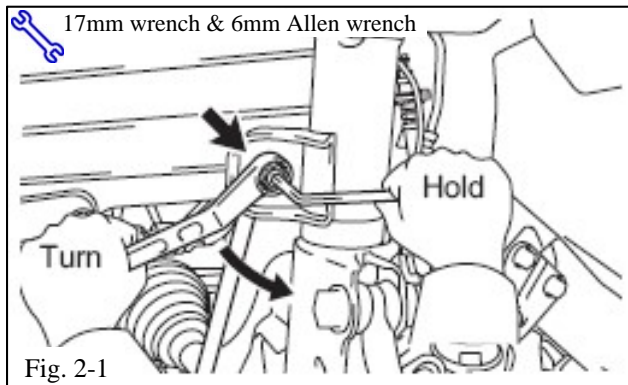

- (a) Remove the front wheels.
- (b) Separate the front stabilizer link from the strut assembly. If the ball joint spins use a 6mm Allen wrench to hold the center stud in place (Fig. 2-1).

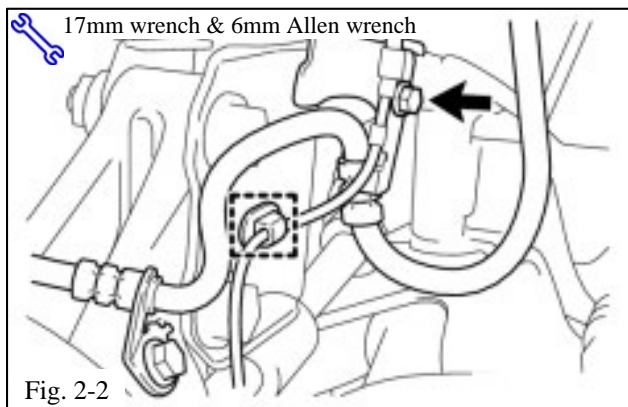

- (c) Separate the front flexible hose and speed sensor wire (Fig. 2-2).

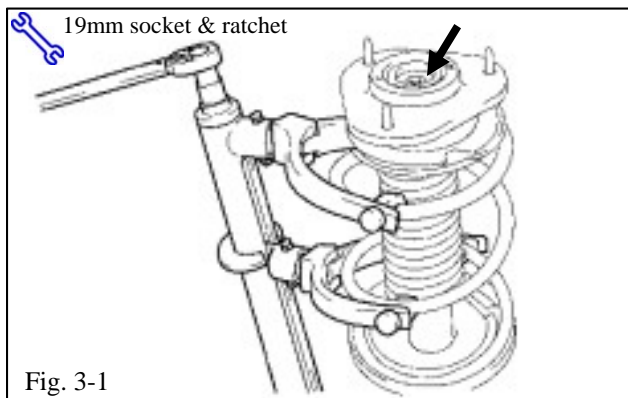
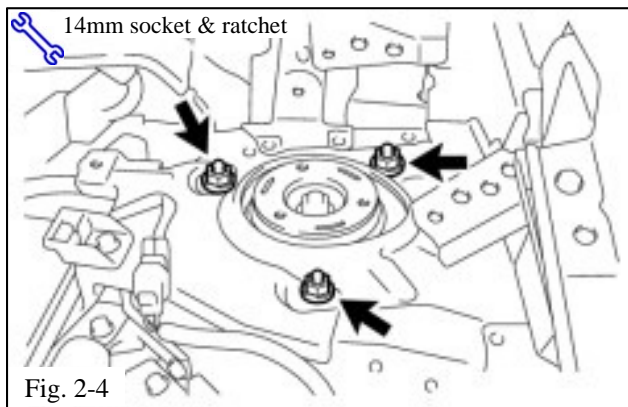
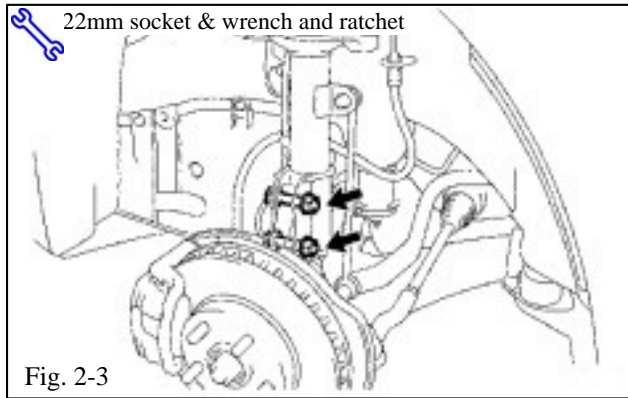

(d) Disconnect the strut assembly from the knuckle (Fig. 2-3).

⚠ CAUTION: Take careful note of the orientation and location of these bolts so that they can be reinstalled the same way.

(e) Remove the strut assembly.

(1) Remove the front suspension support dust cover.

(2) Loosen the 3 nuts fastening the strut to the fender apron (Fig. 2-4).

(3) Support the weight of the strut assembly, then remove the top nuts by hand and remove the strut assembly.

3. Remove the OE Spring.

(a) Compress the spring in a spring compressor.

(b) Remove the upper nut, coil spring seat, bumper and insulator (Fig. 3-1).

(c) Remove the spring.

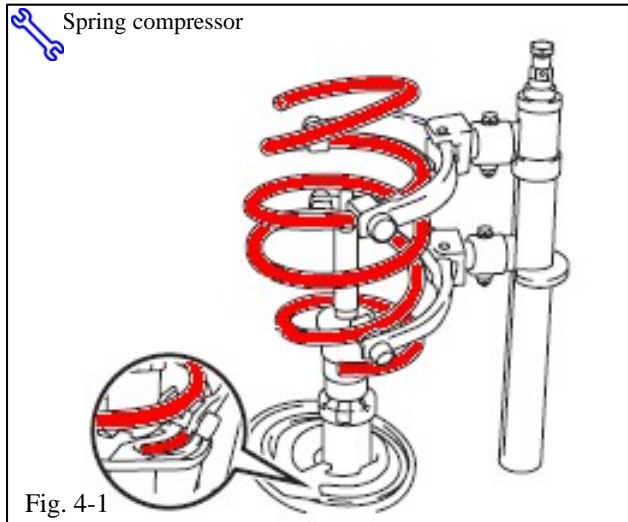

4. Install the New Spring.

(a) Place the new spring over the shock absorber (Fig. 4-1).

(1) The spring wrap with the slightly smaller diameter should be installed in the upward direction and the TRD logo should read right side up.

(2) Fit the lower end of the coil spring into the pocket of the shock absorber lower seat (Fig. 4-1).

(b) **PPO Only:** Install two supplied spring spacers per strut.

(1) Fasten one nylon tie around each spacer.

(2) Cut the excess material protruding from the nylon tie fastener flush to the surface of the fastener.

(c) Install the front spring bumper onto the coil spring seat upper (Fig. 4-2).

(d) Install the coil spring seat upper with the strut mount bearing and spring bumper onto the shock absorber (Fig. 4-2).

(e) Install a **new** shock absorber nut.

(1) Do not force the nut causing the coil spring seat to rotate.

(2) The nut will be fully tightened later, once the strut assembly is reinstalled in the car.

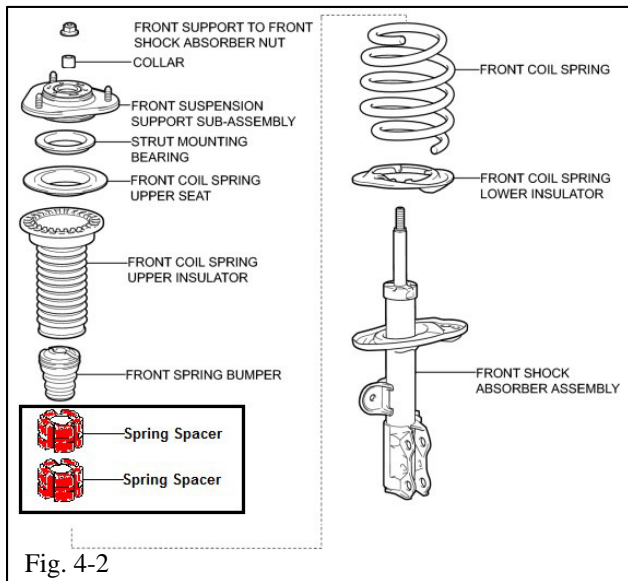

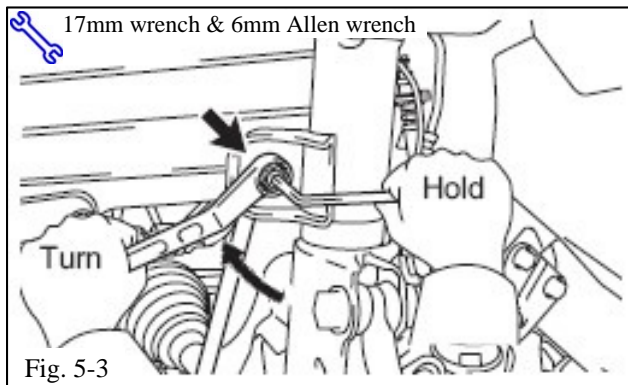
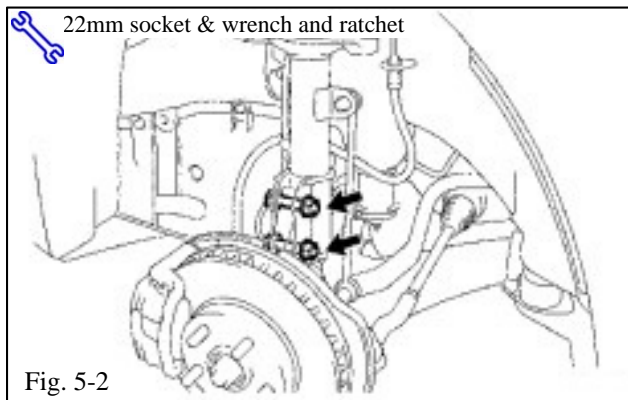
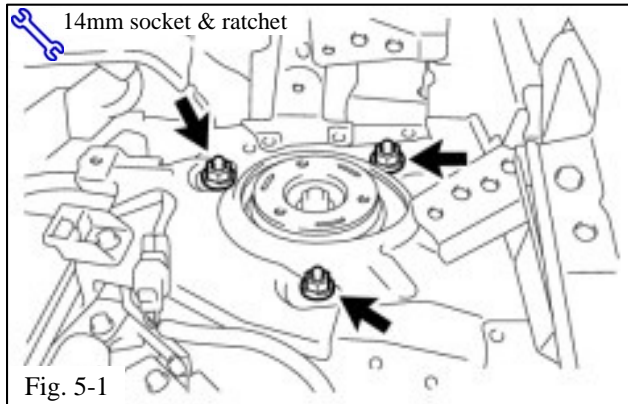

5. Install the Front Strut Assembly.

- (a) Replace the front strut assembly and fasten the 3 nuts (Fig. 5-1).

S Torque: 50 N·m (510 kgf·cm, 37 ft·lbf)

- (b) Attach the strut assembly to the knuckle with the 2 bolts and 2 nuts. Install the bolts in the original orientation (Fig. 5-2).

S Torque: 240 N·m (2447 kgf·cm, 177 ft·lbf)

! NOTE: Do not push or pull on the strut assembly while tightening the nuts as this will alter the factory camber settings.

- (c) Attach the front flexible brake hose and speed sensor (if equipped).

S Torque: 19 N·m (194 kgf·cm, 14 ft·lbf)

! NOTE: Do not twist the hose or sensor line.

- (d) Attach the front stabilizer link assembly. If the ball joint turns together with the nut, use a 6 mm Allen wrench to hold the stud (Fig. 5-3).

S Torque: 74 N·m (755 kgf·cm, 55 ft·lbf)

- (e) Repeat Step 2 through 5(d) on the other side.
- (f) Install the front wheel/tire assemblies onto the vehicle. Hand start the lug nuts.

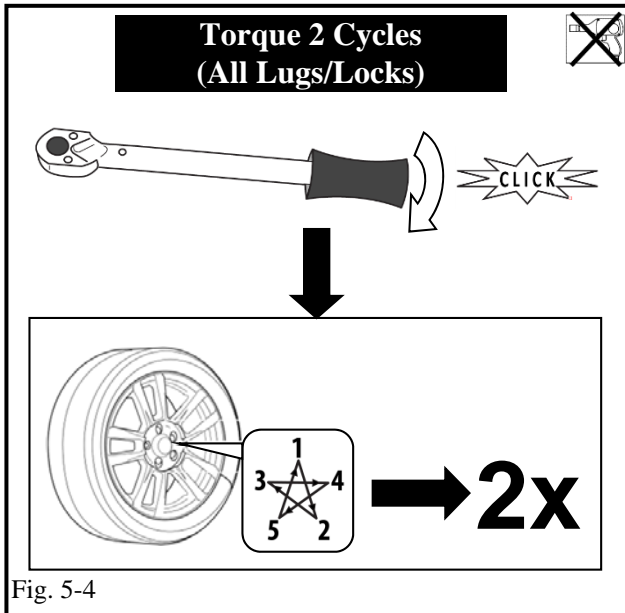

Fig. 5-4

(g) Use a torque wrench to tighten the lug nuts in sequence 1 through 5 to 103N·m (76 ft·lbf) (Fig. 5-4).

S Torque: 103N·m (1,050 kgf·cm, 76 ft·lbf)

STOP (h) Re-torque all of the lug nuts in same the 1-5 sequence (Fig. 5-5).

S Torque: 103N·m (1,050 kgf·cm, 76 ft·lbf)

STOP **CAUTION: DO NOT USE AN IMPACT WRENCH TO INSTALL OR REMOVE WHEEL LOCKS.**
!

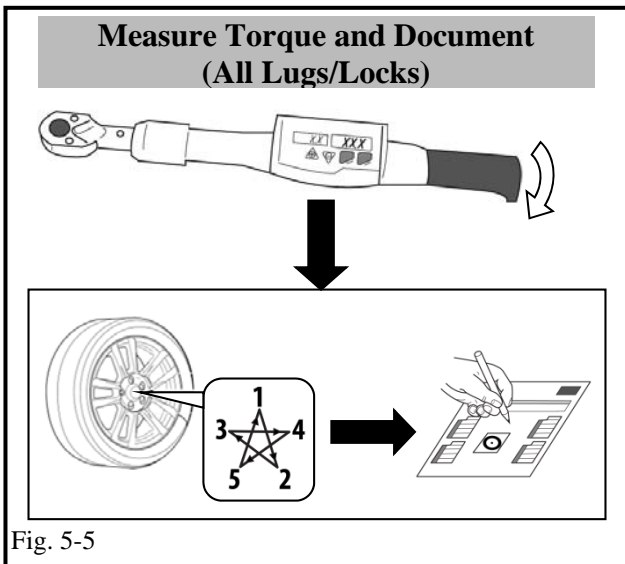

Fig. 5-5

(i) With the vehicle still on the lift, use a digital torque wrench to measure the torque of each lug nut/lock and record it on the Torque Audit Sheet (Fig. 5-5). (PPO installation only. Does not apply to DIO installation.)

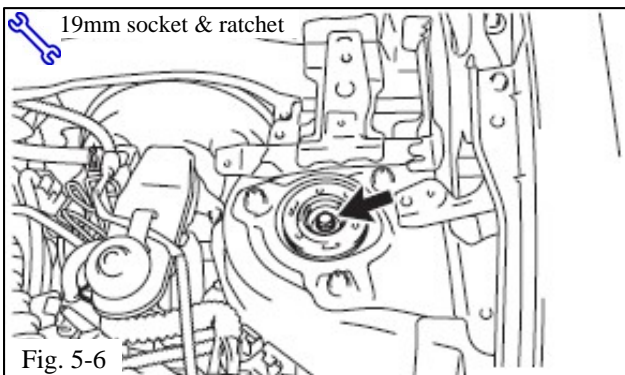
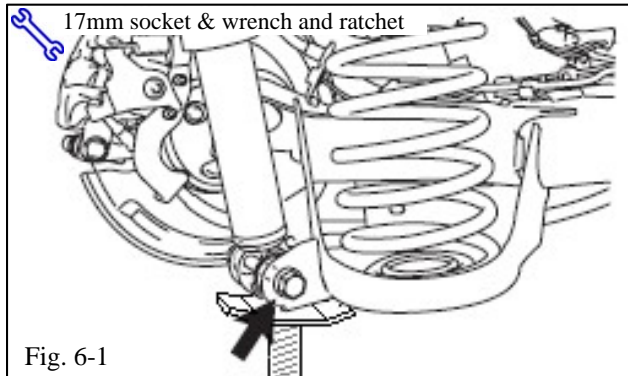

Fig. 5-6

(j) Tighten the upper shock absorber nuts (Fig. 5-6).

S Torque: 47 N·m (479 kgf·cm, 35 ft·lbf)

(k) Install the front suspension support dust cover.



6. Remove the Rear Springs.

- (a) Disconnect the lower shock absorber eye from the axle beam (Fig. 6-1).
 - +** (1) Support the shock absorber mount with a tall jack stand.
 - (2) Remove the bolt.
 - !** **CAUTION:** The nut has a locking feature. Remove the bolt and nut by turning the BOLT while the nut is held in place.
 - (3) Only work on one side of the vehicle at a time to prevent the axle beam from swinging too low and putting excess tension on the beam axle bushings.
- (b) Pull down on the beam axle and lift the bottom of the spring out of the spring seat to remove the spring.

7. Install the New Springs.

- (a) Install the rear spring insulators.
 - !** (1) Confirm the coil spring insulator lower is seated properly on the beam axle.
 - !** (2) Install the coil spring insulator upper so that the pocket fits onto the end of the coil spring (Fig. 7-1).
- (b) Install the new coil spring onto the axle beam.
 - (1) Position the tightly wound coils facing the top of the vehicle.

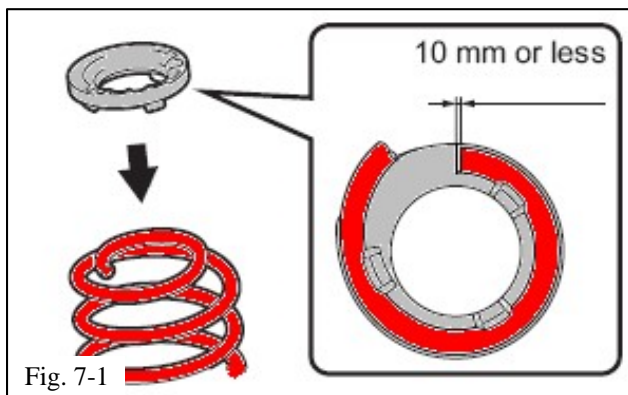

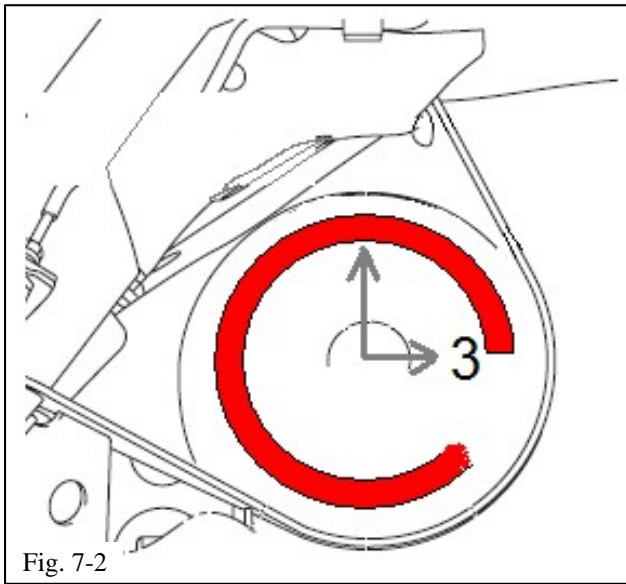

- ⚠ (2) Make sure the bottom ends of the springs are indexed the same left and right. This will ensure equal ride height. The lower ends of the springs should be at the 3 o'clock position (Fig. 7-2).

(c) Reinstall the rear shock absorber lower.

⚠ Torque: 90 N·m (918 kgf·cm, 67 ft·lbf)

8. Install the Cowl and Wiper Assembly.

(a) Install the metal cowl pan (Fig. 8-1).

Torque: 12 N·m (122 kgf·cm, 9ft·lbf)

(b) Install the wiper motor and link assembly.

Torque: 5.5 N·m (56 kgf·cm, 49 in·lbf)

(c) Connect the wire harness and clip the harness to the cowl pan.

(d) Install the cowl top vent louvers (plastic).

(e) Install the wiper arms. Use the clear dots in the black paint at the bottom of the windshield (*1) to indicate the proper wiper blade location (Fig. 8-2).

Torque: 23 N·m (235 kgf·cm, 17 ft·lbf)

(f) **PPO Only:** Place the hang tag on the mirror. The spring spacer removal instructions are to face the windshield.

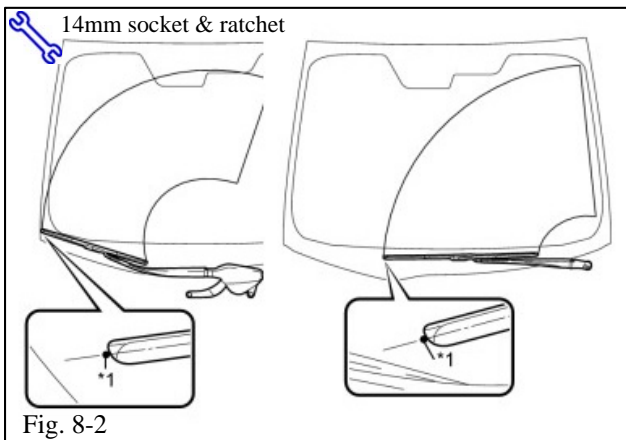
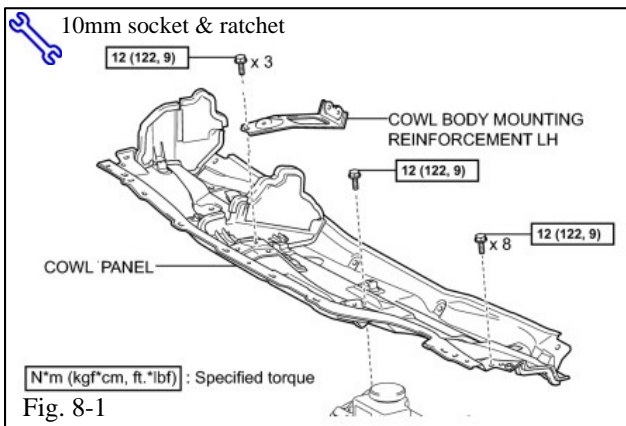

TOYOTA PRIUS 2010 - PLUS LOWERING SPRINGS
 Checklist - these points **MUST** be checked to ensure a quality installation.

Check:	Look For:
<p><u>Accessory Function Checks</u></p> <p><input type="checkbox"/></p> <p><input type="checkbox"/></p> <p><input type="checkbox"/></p> <p><input type="checkbox"/></p>	
<p><u>Vehicle Function Checks</u></p> <p><input type="checkbox"/> Confirm wipers operate properly</p> <p><input type="checkbox"/> All fasteners torqued properly</p> <p><input type="checkbox"/></p>	<p>Proper movement and no windshield contact.</p> <p>Perform a torque audit</p>
<p><u>Vehicle Appearance Check</u></p> <p><input type="checkbox"/> After accessory installation and removal of protective cover(s), perform a visual inspection.</p>	<p>Ensure no damage (including scuffs and scratches) was caused during the installation process. (For PPO installations, refer to TMS Accessory Quality Shipping Standard.)</p>